

# HODEDAH®

## Assembly Instructions

This instruction booklet contains important safety information, please read and keep for future reference.

### ITEM # HIK 77-T (MOP)

MICROWAVE CART



2 people



70 mins



1 YR LTD

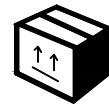

1 Box

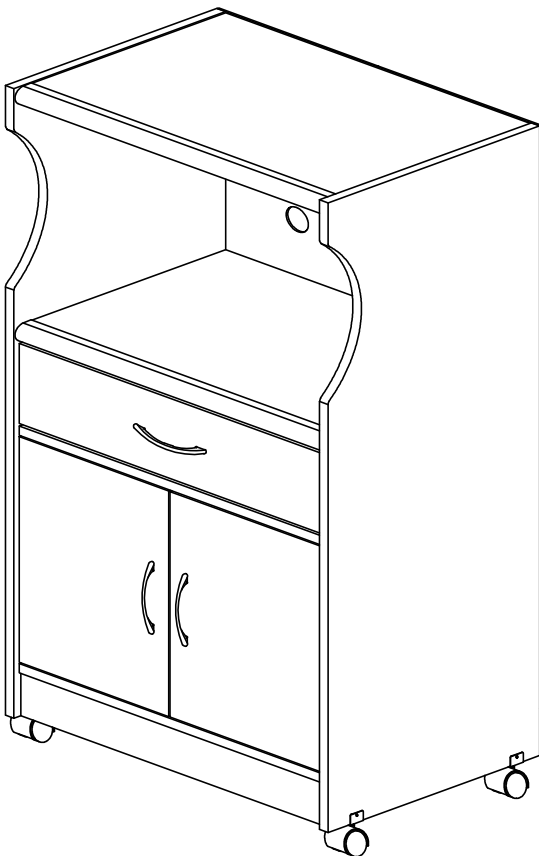

FRONT VIEW

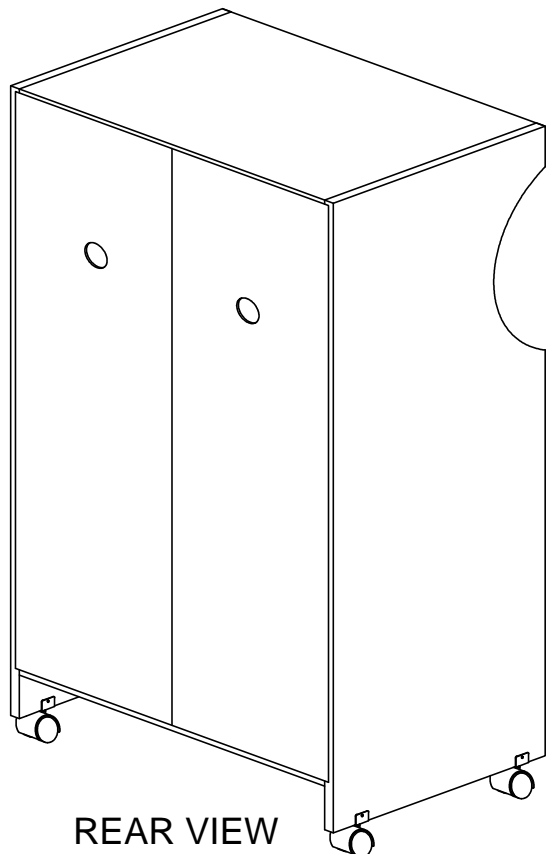

REAR VIEW

**Product Dimensions : Height 23.6" x Width 45.3" x Depth 15.6"**

# HODEDAH®

Questions, need parts, we are here to help!



Phone

Mon - Fri | 9:30am to 5pm EST

1 - 855 - HODEDAH

1 - 855 - 463 - 3324



Email

Send us an email

Support@Hodedah.com



Website

Visit our website to open a case

www.Hodedah.com

FOR PROMPT, RELIABLE SERVICE PLEASE HAVE YOUR INSTRUCTION MANUAL READY



## DO NOT RETURN PRODUCT TO THE STORE

If parts are missing or damaged please contact our customer service team and we will gladly ship your replacement parts FREE of charge within ONE YEAR of purchase!

## WARRANTY

Hodedah warrants this product to be free from defect in materials and workmanship and agrees to remedy and such defect. This warranty covers one year from the date of original purchase. This is solely limited to replacement of defective parts and no assembly for labor is included. This warranty does not apply to any product that has been improperly assembled, subjected to misuse, abuse or which has been altered or repaired in any way. To obtain warranty service, original purchaser must present the following; original bill of sale, date of purchase, where the product was purchased and images if applicable. Components replaced warranted through the remainder of the original warranty only. The defective part will be replaced without charge, subject to the terms and conditions described above.

## WARNING

- This product contains small parts, keep away from children.
- This product contains plastic bags, keep away from children.
- Serious or fatal crushing injuries can occur from furniture tip-over. To help prevent this, place heaviest items on the lower shelves and drawers. Do not set heavy object on top shelves and drawers.
- Never allow children to climb or hang on drawers, shelves and doors.
- Never open more than one drawer at a time.
- The use of tip-over restraints may reduce but not eliminate the risk of tip-over.

# HODEDAH®

## Let's get started...

### Helpful hints, read before beginning assembly

- Make sure you receive all boxes. if your item is packed in one box, box count will read 1 of 1, likewise if your item is packed in two boxes, box count will read 1 of 2 and second box will read 2 of 2.
- Read each step carefully. It is very important that each step is performed in the correct order. If these steps are not followed in sequence, assembly difficulties will occur.
- Work in a spacious level area, preferably carpet, near the place the unit will be used.
- **DO NO USE** power tools to assemble your furniture, it will strip and damage parts.
- Your package should include the following hardware and parts. Parts are labeled or stamped on the raw edge. Please inspect contents to ensure you have received all components. **If you are missing any hardware or parts please contact customer service right away before assembly.**

## Assembly Tools Required (not supplied)

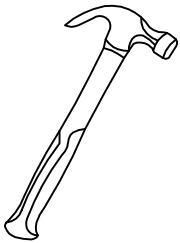

Hammer

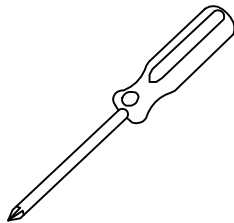

Philips Screwdriver



Tape Measure













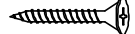

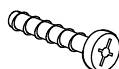



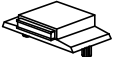

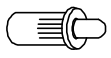

No Power Tools Needed

## Product Care and Maintenance

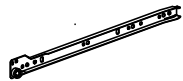
- Wipe clean with dry soft cloth, never use chemicals or cleaning products they will damage the finish.
- Avoid placing your furniture in direct sunlight, as sunlight causes fading.
- Never push, drag or pull your furniture, to move to a new location carefully with two or more people carry the unit to its new location.
- Avoid extreme changes in temperature by arranging furniture away from radiators, heat and air vents and air conditioning units.

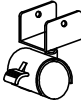

## Hardware List

<b>A1</b>  M6x50MM	<b>QTY</b> 14 Pcs	<b>A2</b>  CSK CAP	<b>QTY</b> 14 Pcs	<b>B</b>  M4X38MM	<b>QTY</b> 10 Pcs
<b>C</b>  M3.5x16MM	<b>QTY</b> 12 Pcs	<b>D1</b>  Moon Handle 96MM	<b>QTY</b> 3 Pcs	<b>D2</b>  M4x22MM	<b>QTY</b> 4 Pcs
<b>E</b>  Allen Key	<b>QTY</b> 1 Pcs	<b>F</b>  Shelf Support	<b>QTY</b> 4 Pcs	<b>G1</b>  Metal Piece	<b>QTY</b> 2 Pcs
<b>G2</b>  3.5KG Magnet (1 Hole)	<b>QTY</b> 2 Pcs	<b>G3</b>  M3X12MM	<b>QTY</b> 2 Pcs	<b>H</b>  Door Support Spring	<b>QTY</b> 4 Pcs
<b>I</b>  M8x25MM	<b>QTY</b> 18 Pcs	<b>J</b>  Nail 5/8	<b>QTY</b> 32 Pcs	<b>K1</b>  Minifix Nut	<b>QTY</b> 6 Pcs
<b>K2</b>  Minifix Bolt	<b>QTY</b> 6 Pcs	<b>K3</b>  Minifix Cap	<b>QTY</b> 6 Pcs	<b>L1</b>  Drawer Slide 14"	<b>QTY</b> 2 Pcs
<b>L2</b>  Drawer Slide 14"	<b>QTY</b> 2 Pcs	<b>M1</b>  Caster With Stopper	<b>QTY</b> 2 Pcs	<b>M2</b>  Caster W/Out Stopper	<b>QTY</b> 2 Pcs

### Important

1. Before you throw the package, please use the Check Box to identify the parts and hardware to ensure that you have everything you need.
2. Check and measure the bolts before applying them to parts.
3. Do not completely tighten all hardware until the entire assembly is complete, unless indicated otherwise.

## Hardware List





M3	QTY	M4	QTY
	4		4
Caster's Screw	Pcs	Caster's Nut	Pcs

### Important

1. Before you throw the package, please use the Check Box to identify the parts and hardware to ensure that you have everything you need.
2. Check and measure the bolts before applying them to parts.
3. Do not completely tighten all hardware until the entire assembly is complete, unless indicated otherwise.

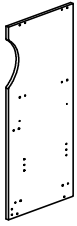
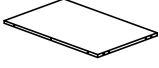
# HODEDAH®

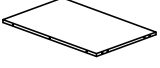
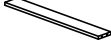
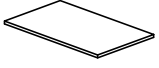
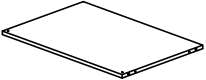
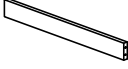
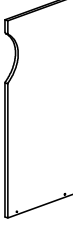
## Parts List

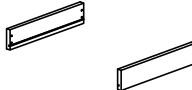
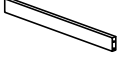
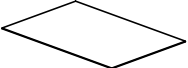
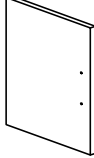
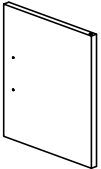
1  1100x394x15mm	QTY 1 Pcs	2  568x362x15mm	QTY 1 Pcs	3  568x30x30mm	QTY 2 Pcs
4  568x362x15mm	1 Pcs	5  568x76x15mm	1 Pcs	6  568x340x15mm	1 Pcs
7  568x384x15mm	1 Pcs	8  568x76x15mm	1 Pcs	9  1100x394x15mm	1 Pcs
10  1018x297x2.5mm	2 Pcs	11  560x140x15mm	1 Pcs	12  350x90x15mm	2 Pcs
13  512x60x15mm	1 Pcs	14  522x350x2.5mm	1 Pcs	15  394x278x15mm	1 Pcs
16  394x278x15mm	1 Pcs				

# HODEDAH®

## The Breakdown...

### I) Main Unit :

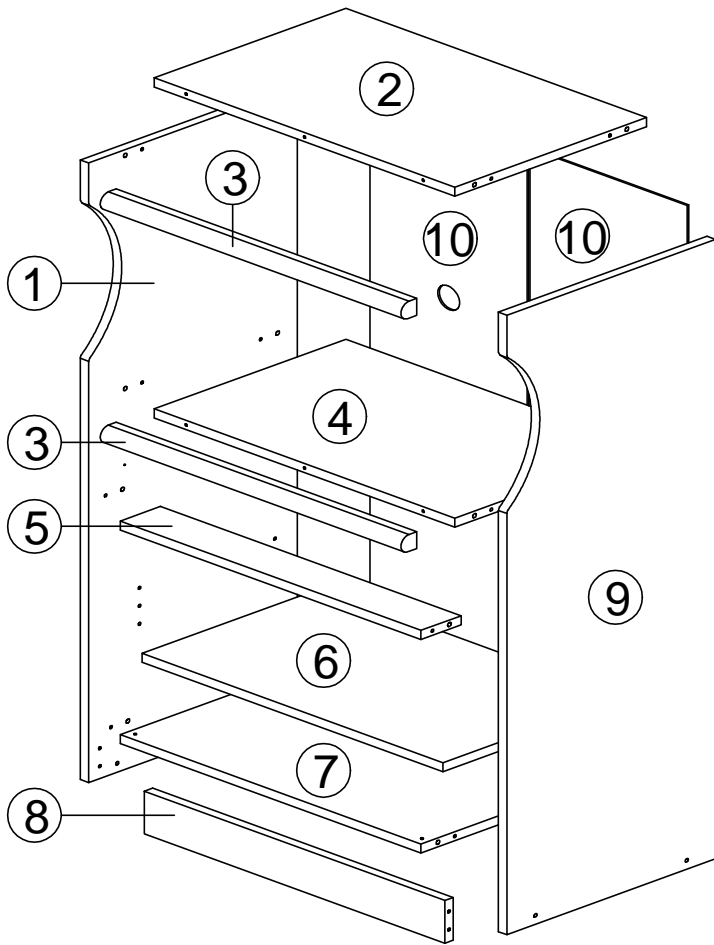

### II) Door & Drawer :

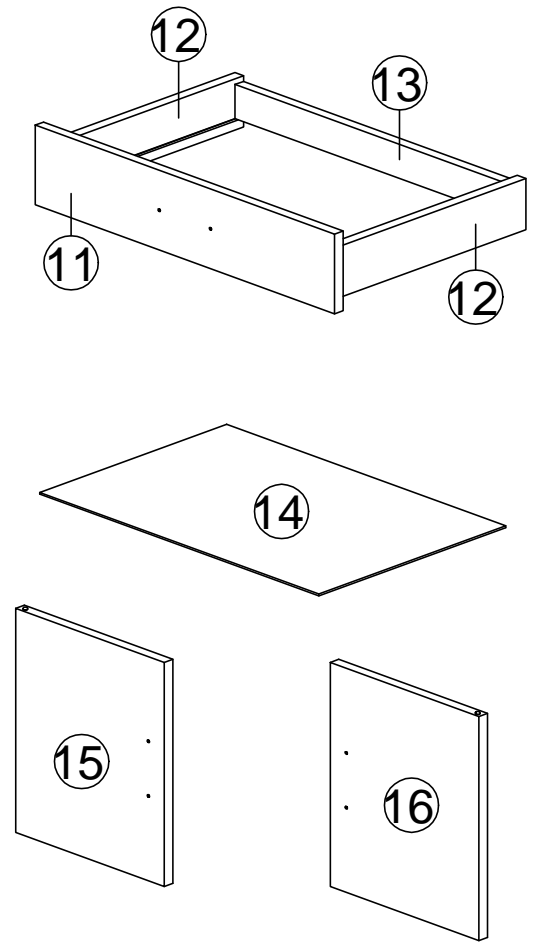

# HODEDAH®

## Step 1

I	 WOOD DOWEL M8x25MM	18
---	--	----

K2	 MINIFIX BOLT	6
----	--	---

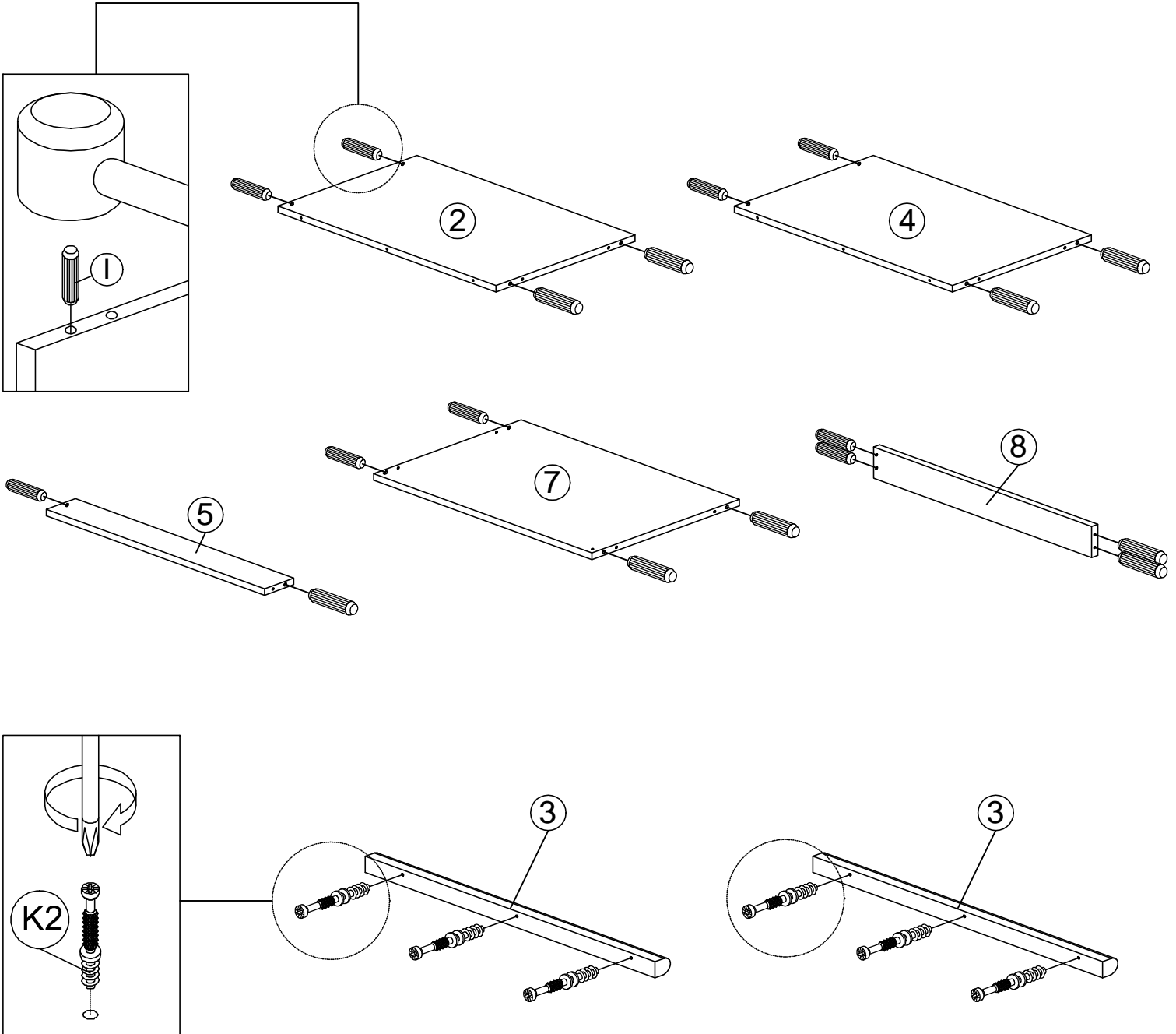



1. Insert 18 x wood dowels (I) into panel (2,4,5,7 & 8).
2. Tighten 6 x minifix bolt (K2) into 2 x panel (3).



# HODEDAH®

## Step 2

L1		DRAWER SLIDE "14	2
C		CB SCREW M3.5X16MM	6
H		DOOR SUPPORT SPRING	4

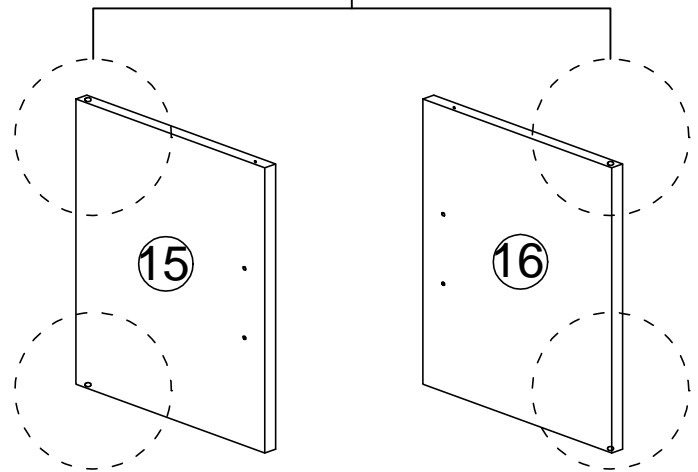
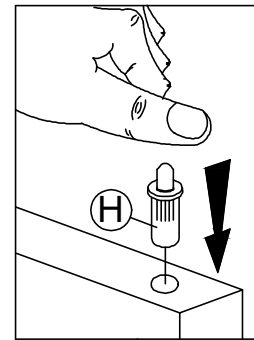
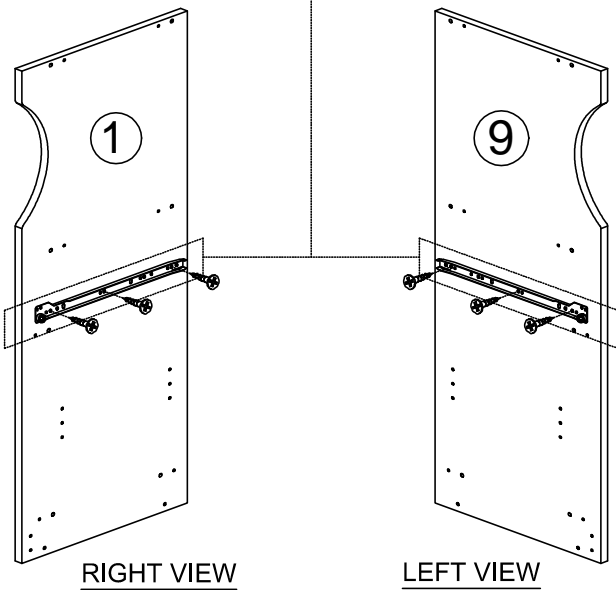
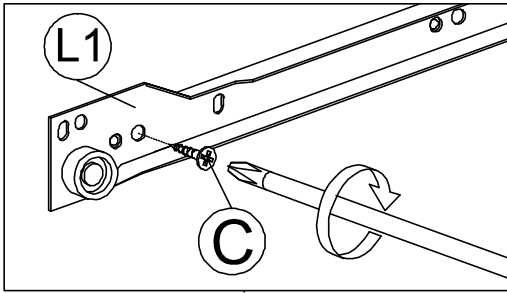

1. Place drawer slide (**L1**) onto 3 holes area shown at right view side panel (**1**). Then tighten it with 3 x cb screws M3.5x16mm (**C**).
2. Place drawer slide (**L1**) onto 3 holes area shown at left view side panel (**9**). Then tighten it with 3 x cb screws M3.5x16mm (**C**).
3. Insert 4 x door support spring (**H**) into door panel (**15 & 16**) top side and bottom side.

# HODEDAH®

## Step 3

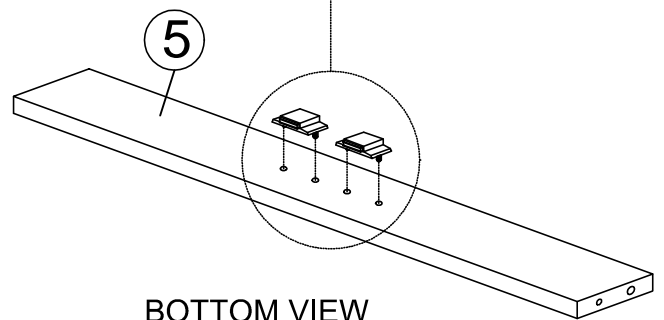
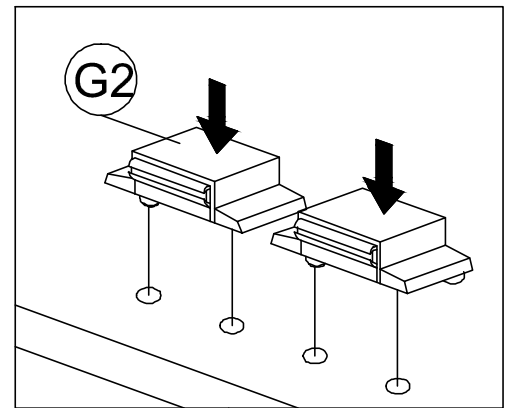
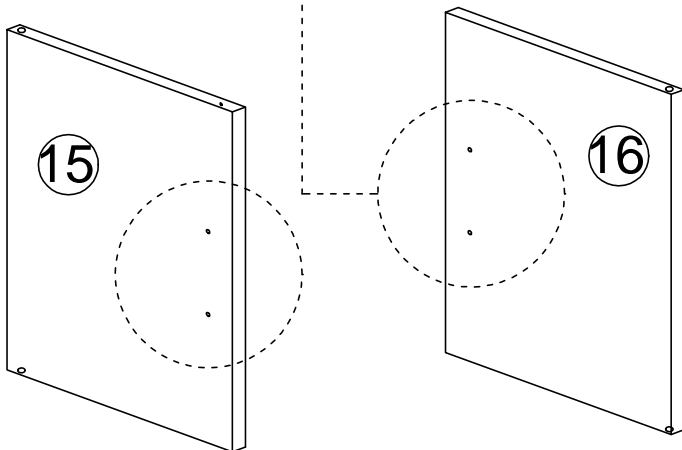
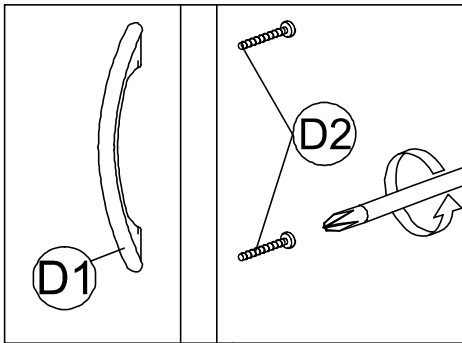

D1		MOON HANDLE 96MM	2
D2		P/H SCREW M4X22MM	4
G2		3.5KG MAGNET (1 HOLE)	2



BOTTOM VIEW

1. Tighten 4 x P/H screws M4x22mm (**D2**) from door panel (**15 & 16**) back side into the 2 x handle (**D1**) 's holes.
2. Insert 2 x magnet (**G2**) into panel (**5**) bottom side.

## Step 4

F		SHELF SUPPORT	4
G1		METAL PIECE	2
G3		CB SCREW M3X12MM	2

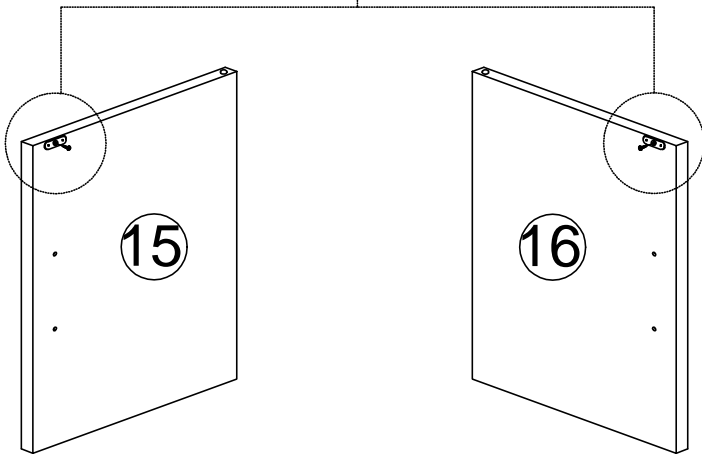
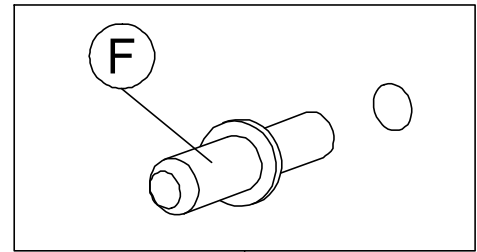
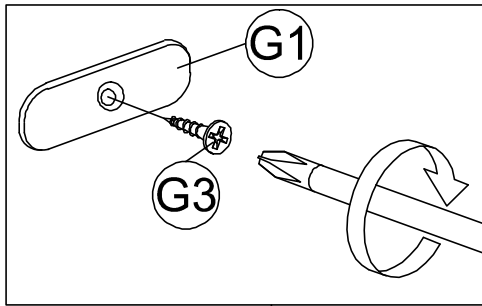

RIGHT VIEW

LEFT VIEW

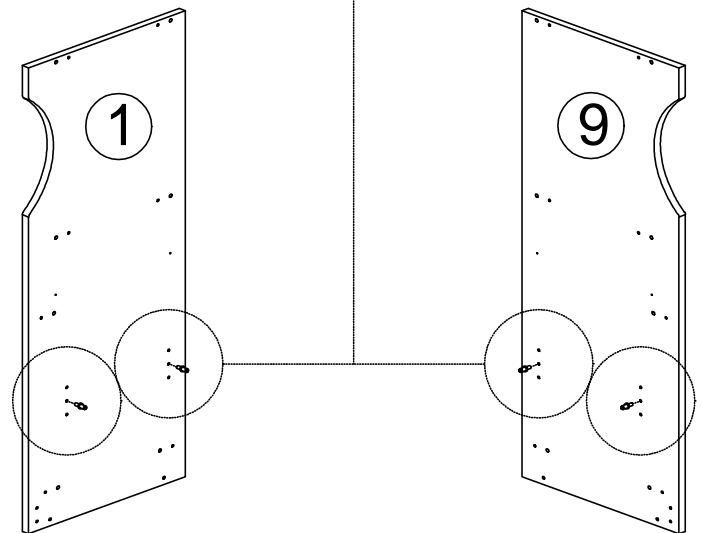



RIGHT VIEW



LEFT VIEW

1. Fix & tighten 2 x metal piece (**G1**) by using 2 x cb screws M3x12mm (**G3**) to door panel (**15 & 16**) as shown.
2. Insert 4 x shelf support (**F**) into panel (**1 & 9**).

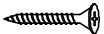
# HODEDAH®

## Step 5

B		CB SCREW M4X38MM	10
C		CB SCREW M3.5X16MM	6
D1		MOON HANDLE 96MM	1

L2		DRAWER SLIDE "14	2
J		NAIL 5/8	10

(1)

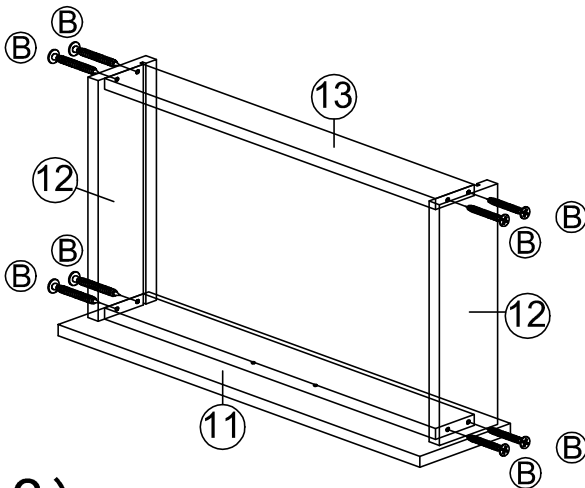

(2)

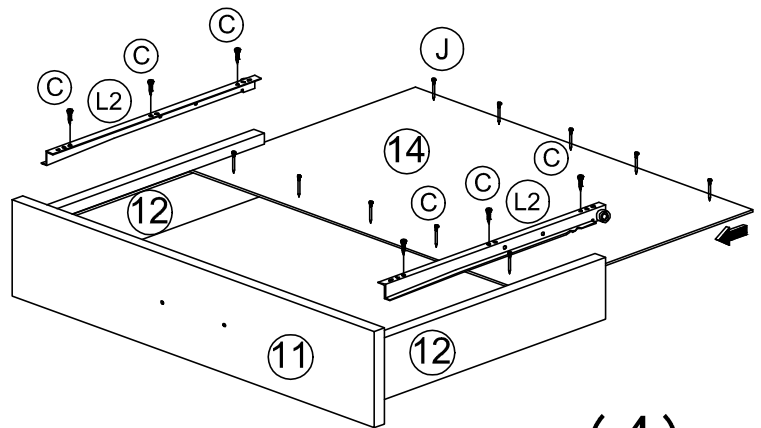

(3)

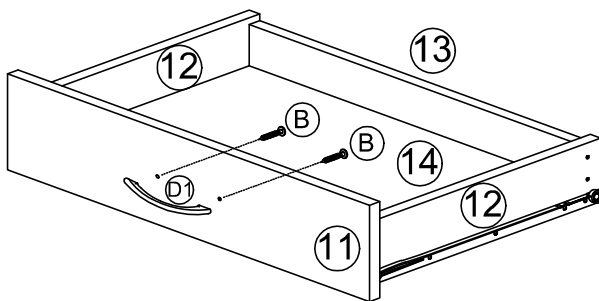

(4)

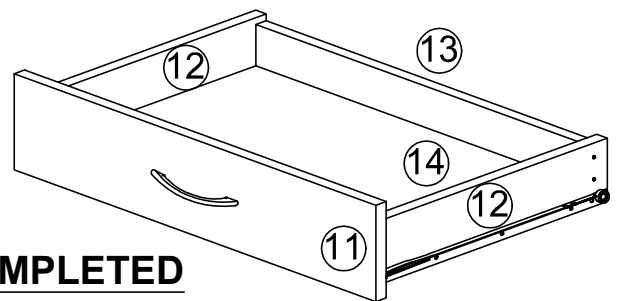

**COMPLETED**

1. Place 2 x panel (12) next to each side of panel (11&13). **(As Shown)**. Then tighten 8 x screws (B) from the sides of panel (12) to the edges of panel (11&13) with screwdriver.
2. Flip drawer bottom side up, take panel (14) and slide it into the groove of side panel (12). Then using 10 x nails (J) with hammer nails into the edges thru panel (14) onto panel (11 # Drawer front) and panel (13 # Drawer back).
3. Then place drawer slides (L2) onto the edges of panels (12 #Both sides) and screw in three Letter (C) screws onto each hole of the drawer slides connecting it to panels (12) with screwdriver. **(As Shown)**.
4. Flip down around and attach (D1) handle to front panel (11) using 2 x screws (B) from the inner side panel (11) with screwdriver.

# HODEDAH®

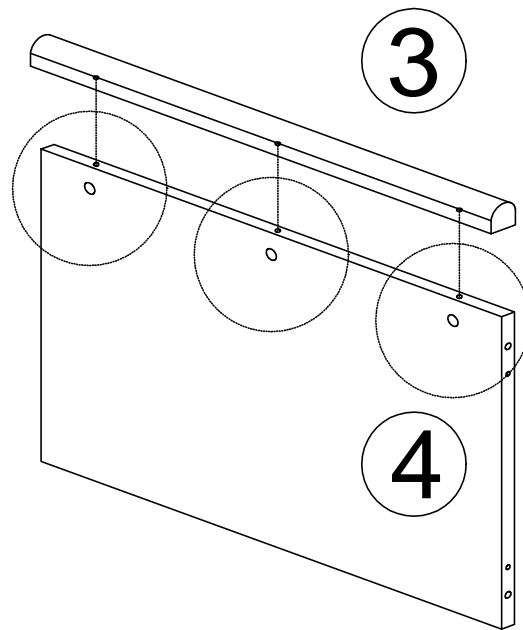
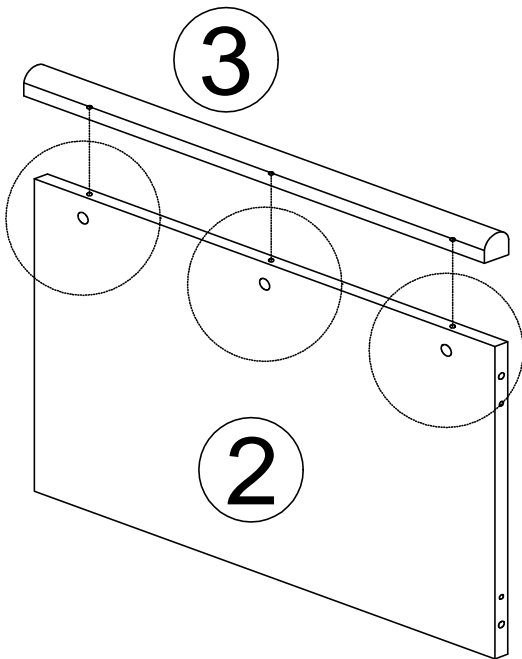
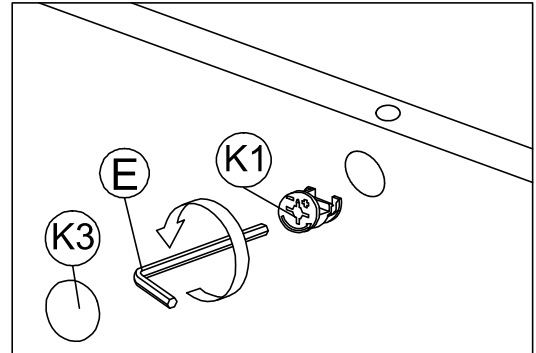

## Step 6

E		ALLEN KEY	1
K1		MINIFIX NUT	6
K3		MINIFIX CAP	6



1. Place panel (3) to panel (2 & 4) by using 6 x minifix nut (K1), onto 3 thru-holes as shown at panel (2 & 4) with allen key (E) to tighten it. After that insert 6 x cap (K3).

## Step 7

A1		CSK CAP WOOD M6X50MM	7
A2		CSK CAP	7
E		ALLEN KEY	1

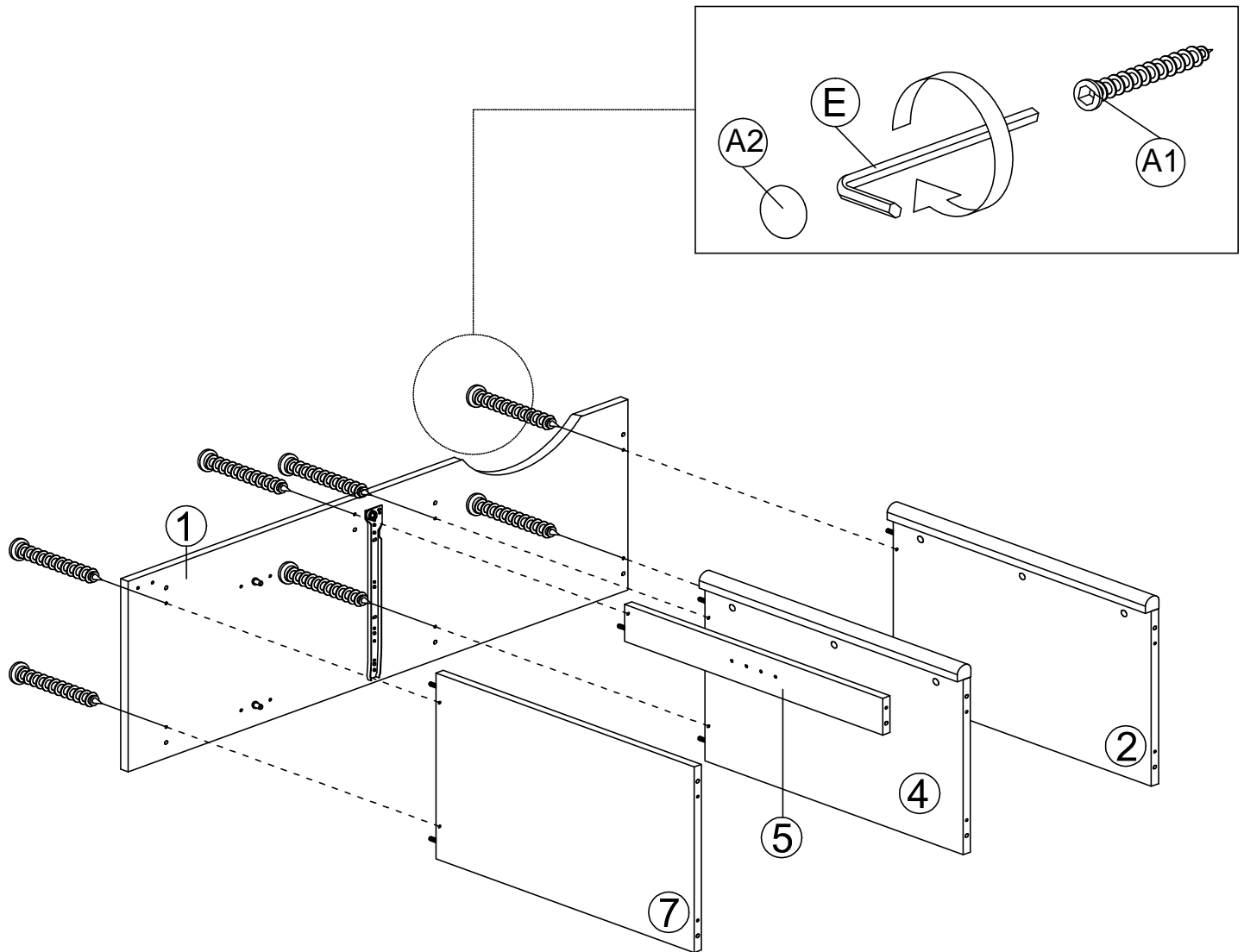

1. Fix panel (2,4,5 & 7) to panel (1) by using dowels (I) onto non-thru at panel (1) and tighten 7 x csk M6x50mm (A1) from the thru-holes of panel (1) with allen key (E). After that insert 7 x cap (A2).

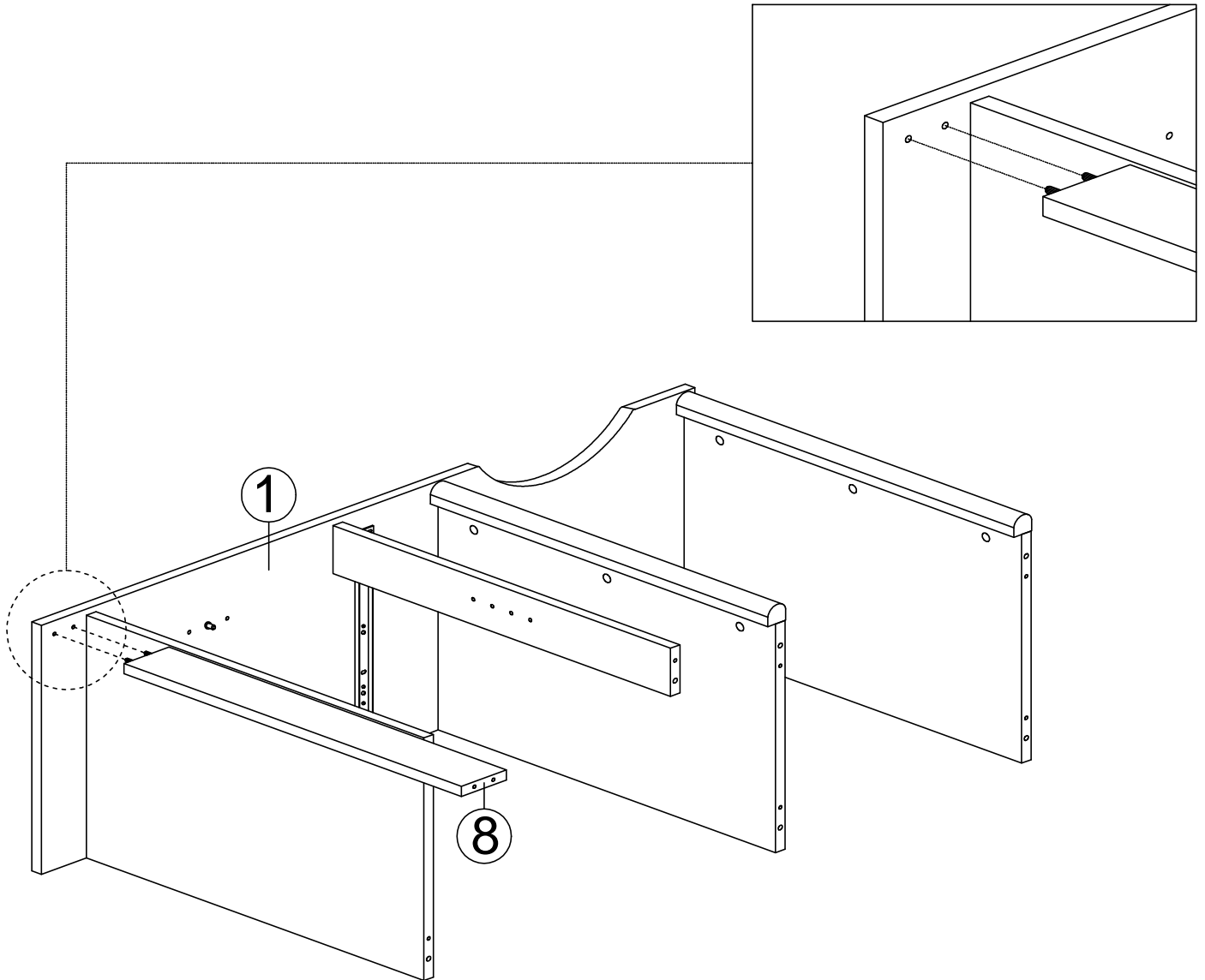

## Step 8



1. Fix panel **(8)** to panel **(1)** by using dowels **(I)** onto thru-holes as shown at panel **(1)**.

# HODEDAH®

## Step 9

A1		CSK CAP WOOD M6X50MM	7
A2		CSK CAP	7
E		ALLEN KEY	1

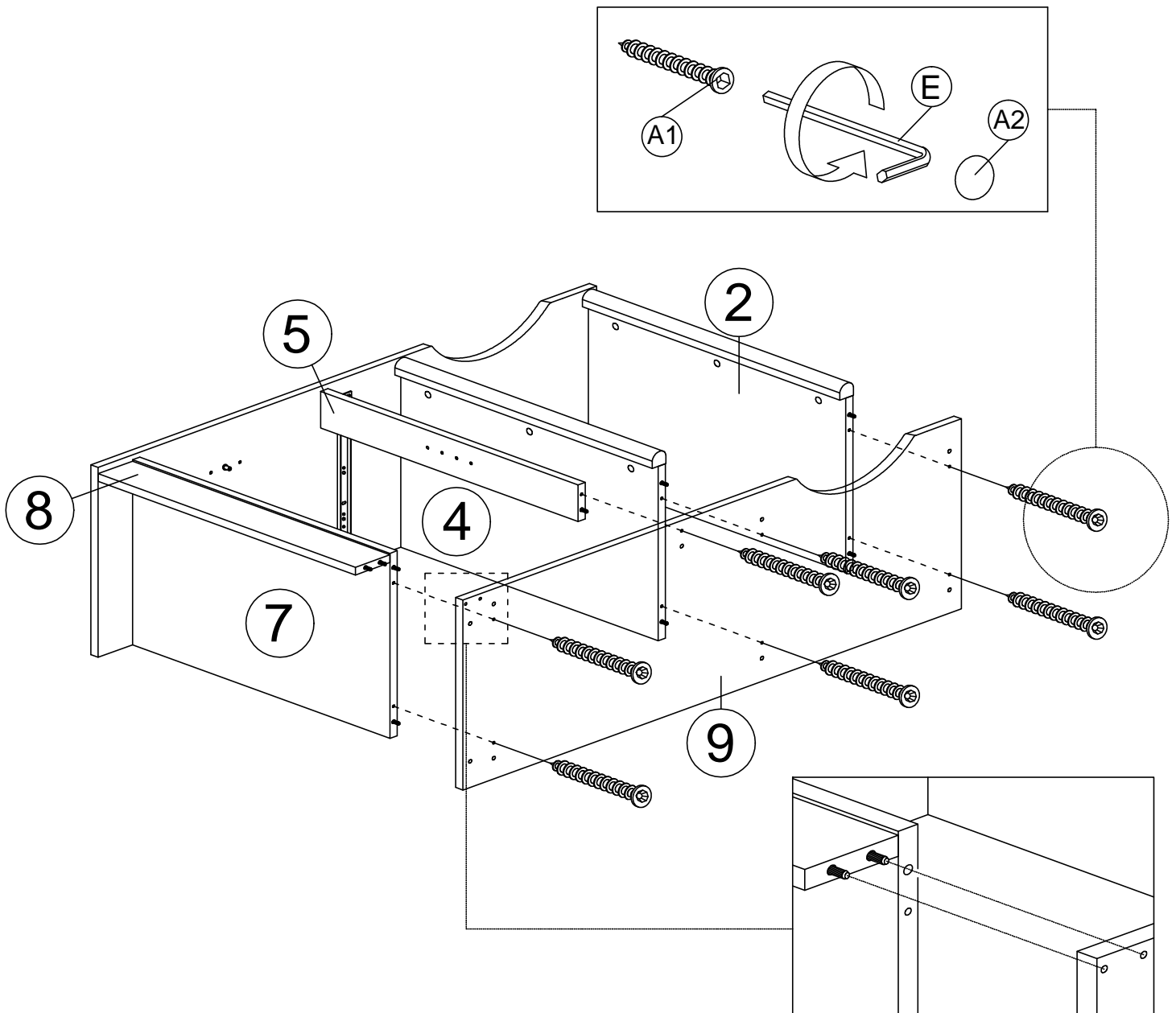



1. Fix panel (9) to panel (2,4,5,7 & 8) by using dowels (I) onto non-thru at panel (2,4,5,7 & 8) and tighten 7 x csk M6x50mm (A1) from the thru-holes of panel (9) with allen key (E). After that insert 7 x cap (A2).



# HODEDAH®

## Step 10

M1		CASTER WITH STOPPER	2
M2		CASTER W/OUT STOPPER	2
M3		CASTER'S SCREW	4

M4		CASTER'S NUT	4
----	---	--------------	---

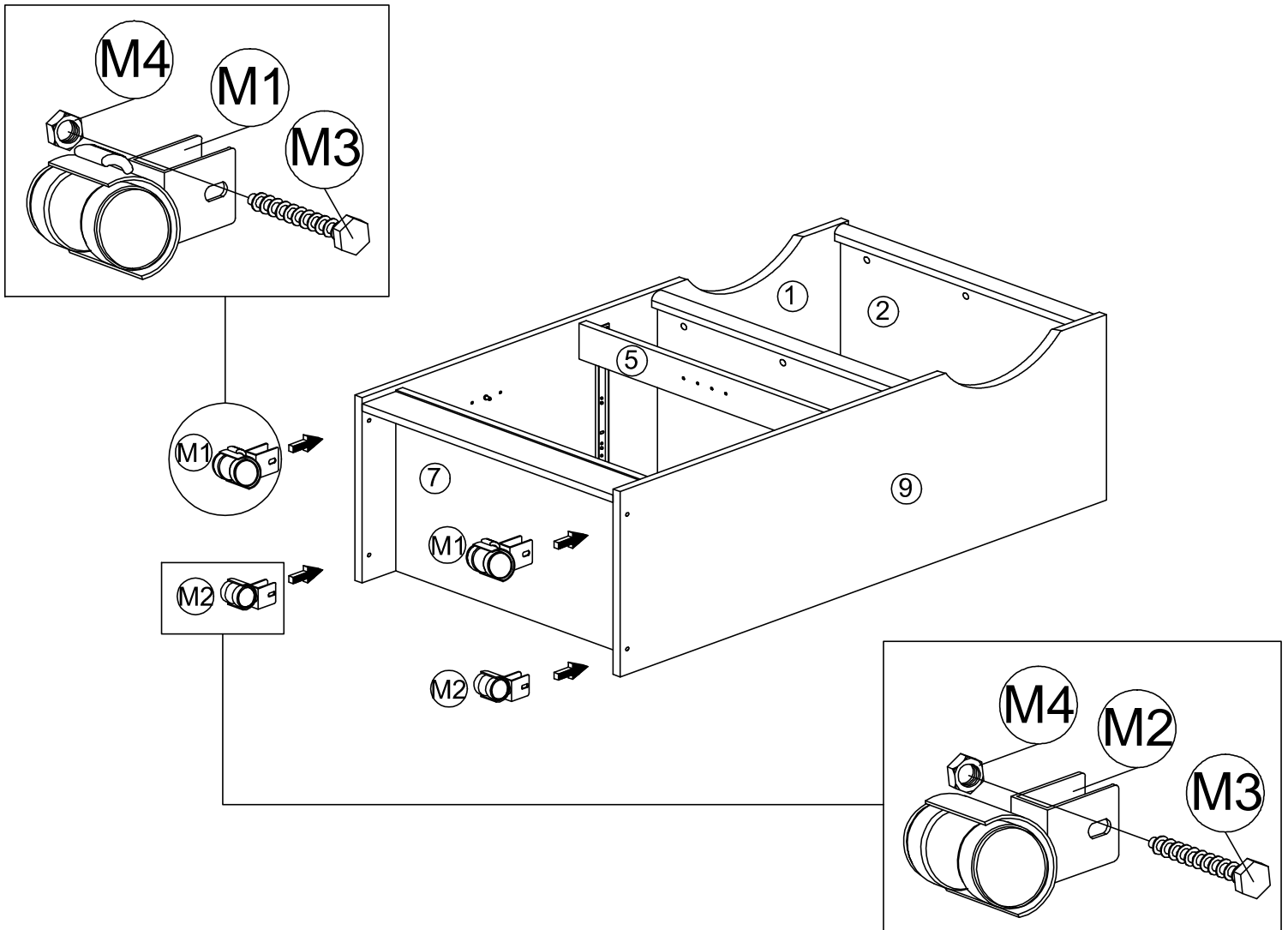

1. Take caster (**M1 & M2**) insert with (**One By One**) and push the caster's screw (**M3**) thru from outside to inside, then tighten the nut (**M4**) as shown for all 4 casters.

# HODEDAH®

## Step 11

J		NAIL 5/8	22
---	---	----------	----

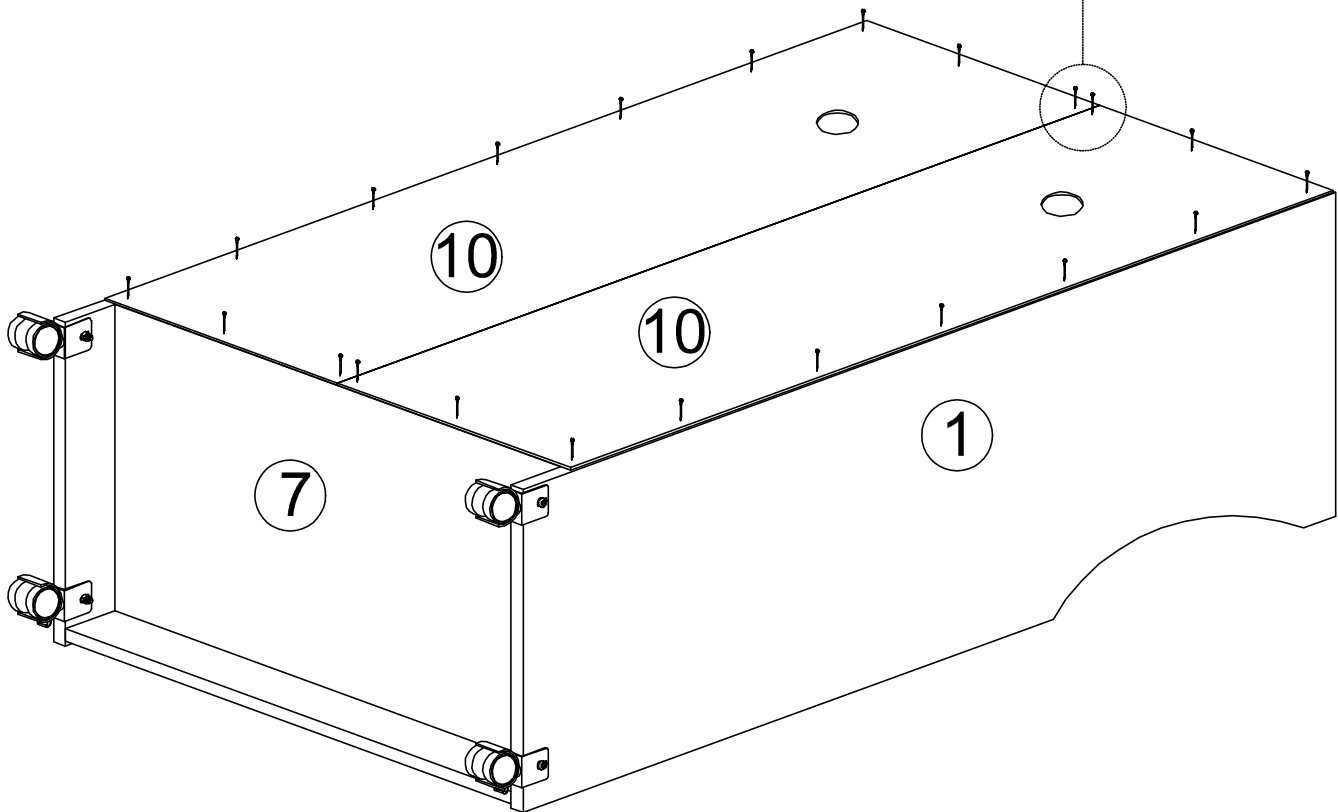
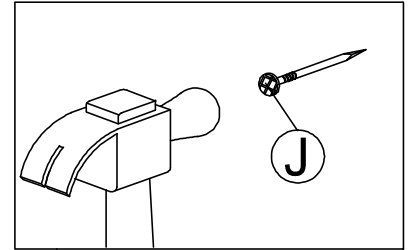

1. At face down position, place 2 x panel **(10)** onto the back of the main unit and align it properly for nailing. Use hammer to nail the nails one by one on the line drawn and at center of 4 side edges. Gap between 2 nails should be about 203mm for all.

## Step 12

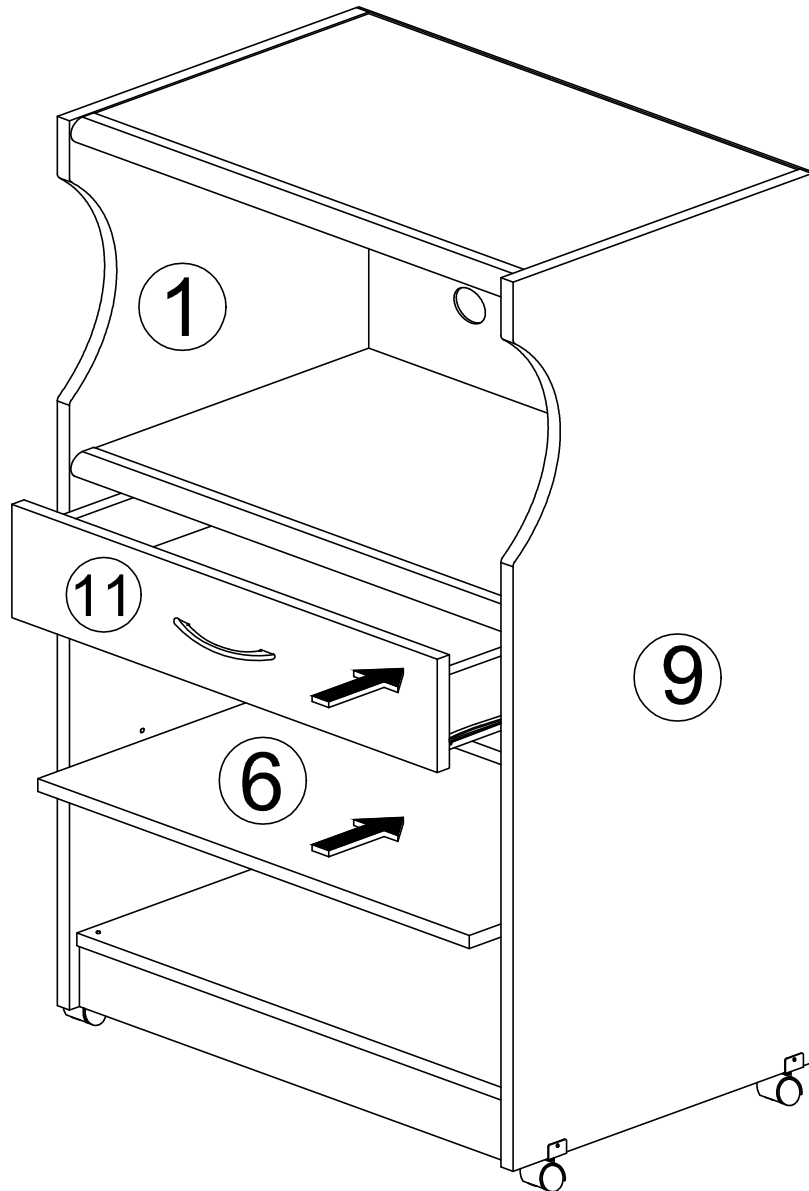

1. Slide in the drawer (11) by slotting the rollers at each end of drawer slide (L2) onto the rail of drawer slide (L1) fixed at side panel (1 & 9). Then push the drawer in slowly.
2. Take panel (6) and slide it inside the top compartment by putting it on the 4 shelf support as shown.

# HODEDAH®

## Step 13

### Final step...

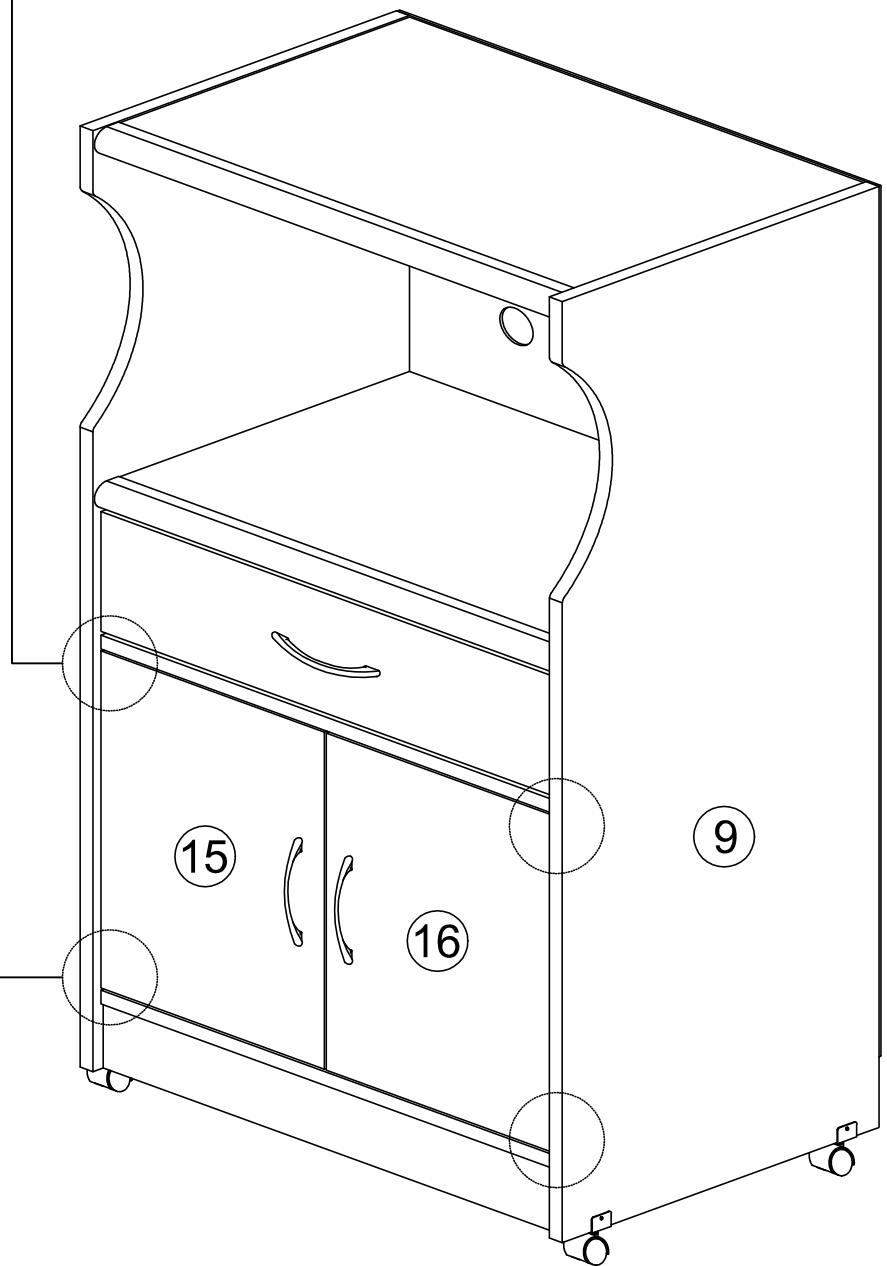
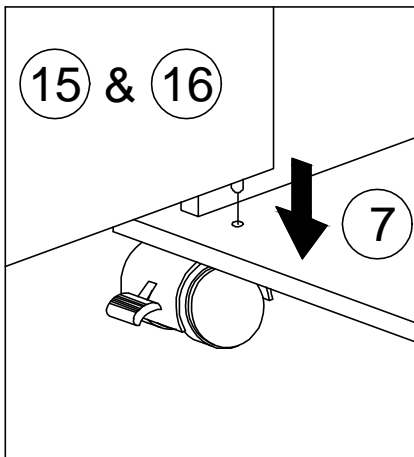
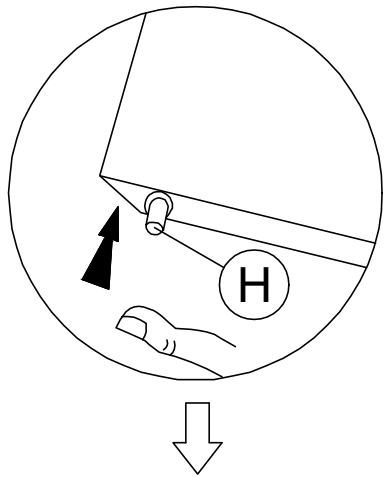
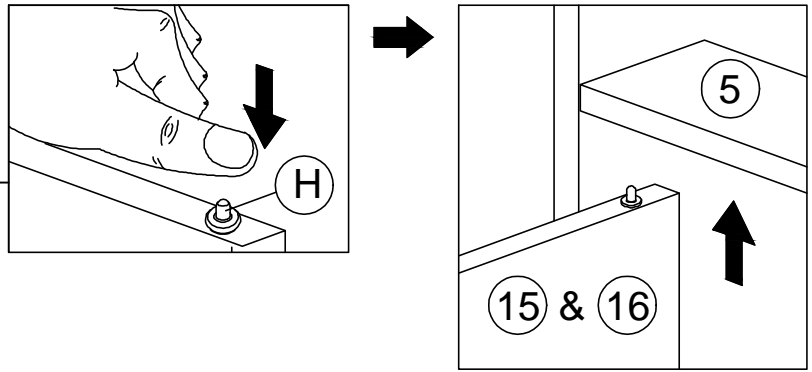

1. Press the door support spring (H) at the panel (15 & 16) top side. After that, inside to the holes at panel (5).
2. Press the door support spring (H) at the panel (15 & 16) bottom side. After that, inside to the holes at panel (7).

# HODEDAH®

## Job Complete...

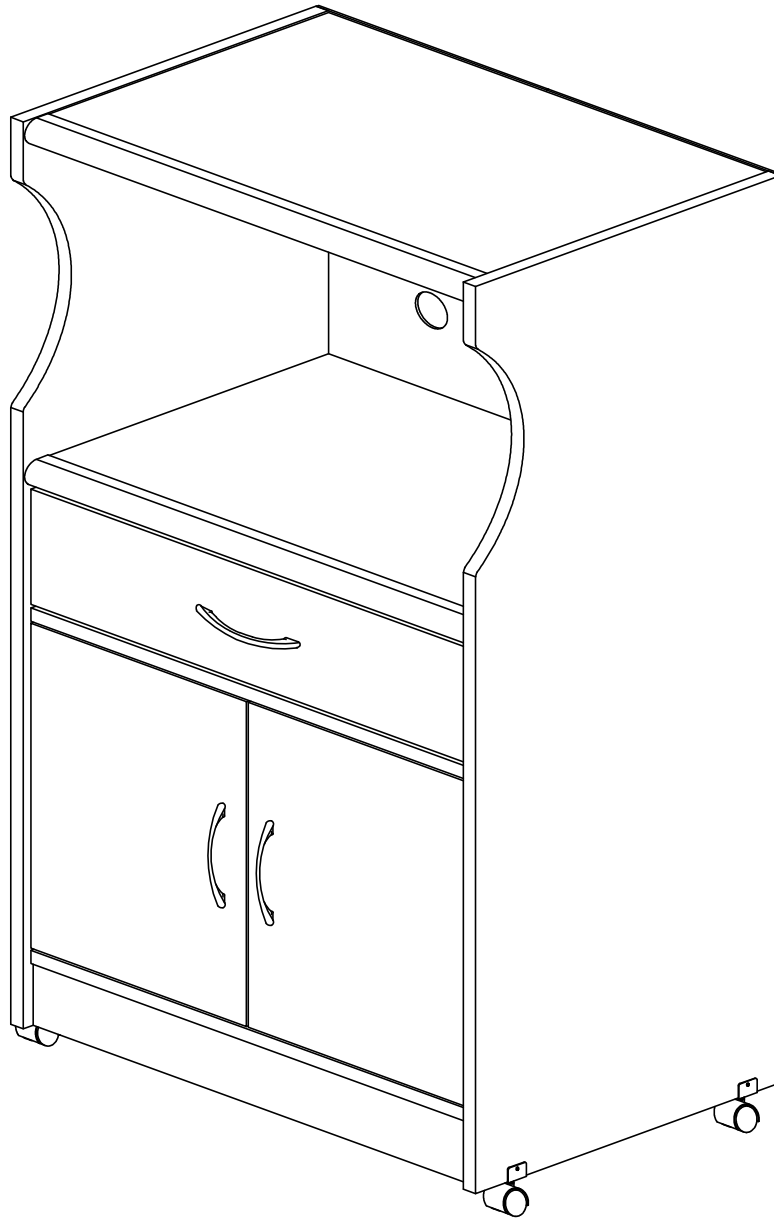

Enjoy & Thank you for purchasing from Hodedah!



# HODEDAH®

## Installation of Anti-Tip Restraint

Kit includes:

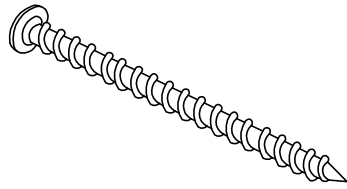

**A (x2)**  
Long screw

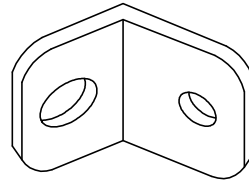

**B (x4)**  
Mounting bracket

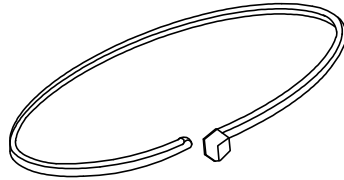

**C (x2)**  
Restraint strap

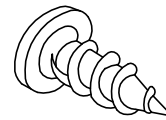

**D (x2)**  
Short screw



# WARNING



**Serious or fatal crushing injuries can occur from furniture tip-over. To help Prevent tip-over:**

- Install tip-over restraint provided
- Place heaviest items in the lower drawers
- Do not set TV's or other heavy objects on top of this product
- Never allow children to climb or hang on drawers, doors or shelves
- Never open more than one drawer at a time
- Do not defeat or remove the drawer interlock system

**Use tip-over restraints may only reduce but not eliminate the risk of tip-over.**

**IMPORTANT:** Use of this safety kit is mandatory. This restraint is not a substitute for proper adult supervision. Failure to detach this restraint before moving furniture may result in injury and damage. **If the safety kit is not in the box, please contact our consumer service team at Tel. 1 (718) 456 0505 or Email [Support@Hodedah.com](mailto:Support@Hodedah.com) in order to obtain one before using the furniture.**

## FITTING OF ANTI-TIP SAFETY STRAP

### STEP 1:

- Attach the mounting bracket (b) to the furniture in the solid part below the top panel a few inches away from the side of the unit.
- Screw (d) through the smallest hole of (b).

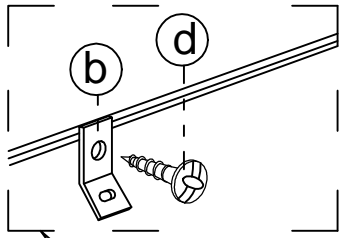

### STEP 2:

- Locate a stud in behind the have to
- Place the other mounting bracket (b) on the wall stud 2 inches below the mounting bracket secured to the back of your unit.
- Attach to the wall stud using (c) through the smaller hole of (b).

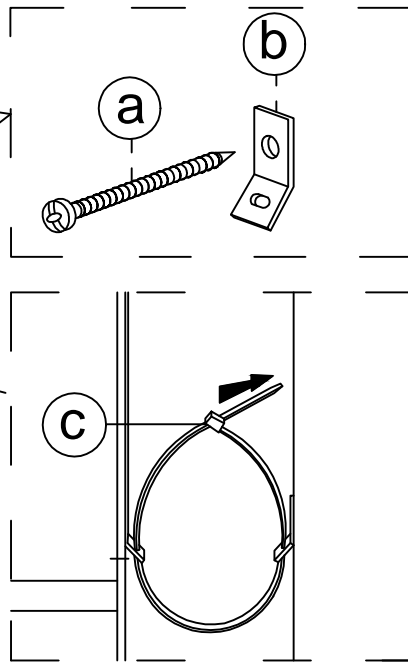

### STEP 3:

- Repeat the same step a few inches away from the other side of the unit.
- Place the furniture into position so both mounting brackets are vertically in line.
- Lace the end of the restraint strap through the larger holes in each mounting bracket.
- Secure the straps and lock into place.

