

HODEDAH®

Assembly Instructions

This instruction booklet contains important safety information, please read and keep for future reference.

ITEM # HID8600-G

2 DOOR WARDROBE



2 people



90 mins



1 YR LTD



2 Boxes

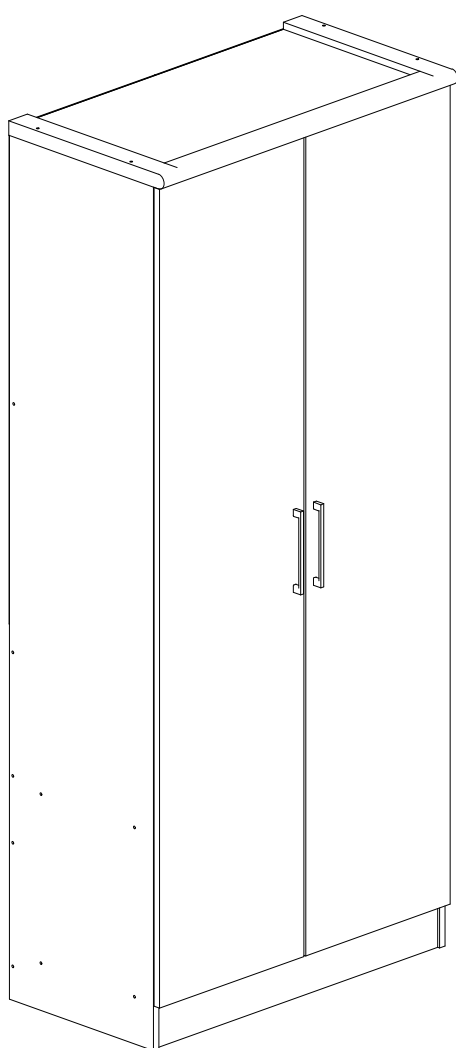

FRONT VIEW

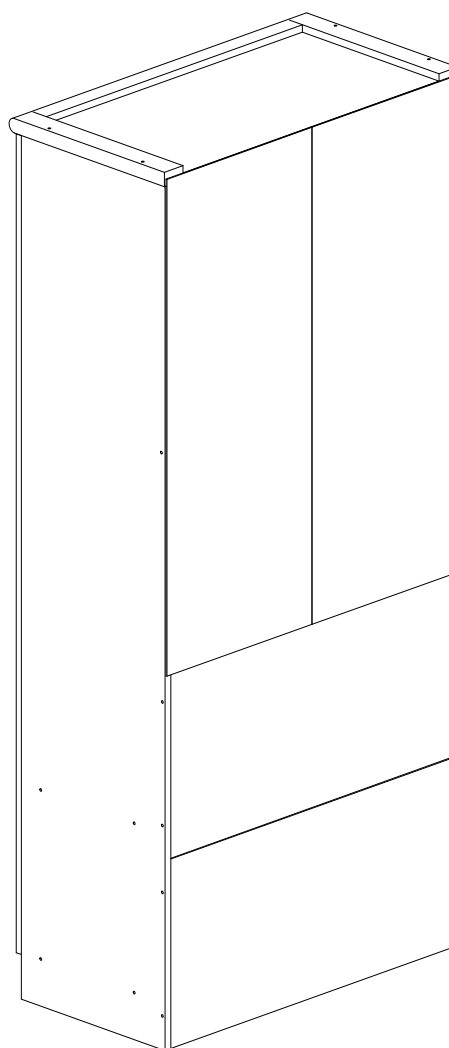

BACK VIEW

Product Dimensions: Height 71.61" x Width 31.50" x Depth 16.73"

Weight Capacity Per Shelf 30lbs

HODEDAH®



Phone

Mon - Fri | 9:30 am to 5pm EST

1 - 855 - HODEDAH

1 - 855 - 463 -3324



Email

Send us an email

Support@Hodedah.com



Website

Visit our website to open a case

www.Hodedah.com

Questions, need parts, we are here to help!

FOR PROMPT, RELIABLE SERVICE PLEASE HAVE YOUR INSTRUCTION MANUAL READY



DO NOT RETURN PRODUCT TO THE STORE

If parts are missing or damaged please contact our customer service team and we will gladly ship your replacement parts FREE of charge within **ONE YEAR** of purchase!

WARRANTY

Hodedah warrants this product to be free from defects in materials and workmanship and agrees to remedy any such defect. This warranty covers one year from the date of original purchase. This is solely limited to replacement of defective parts and no assembly for labor is included. This warranty does not apply to any product that has been improperly assembled, subjected to misuse, abuse or which has been altered or repaired in any way. To obtain warranty service, original purchaser must present the following; original bill of sale, date of purchase, where the product was purchased and images if applicable. Components replaced warranted through the remainder of the original warranty only. The defective part will be replaced without charge, subject to the terms and conditions described above.

WARNING

- This product contains small parts, keep away from children.
- This product contains plastic bags, keep away from children.
- Serious or fatal crushing injuries can occur from furniture tip-over. To help prevent this, place heaviest items on the lower shelves and drawers. Do not set heavy objects on top shelves and drawers.
- Never allow children to climb or hang on drawers, shelves and doors.
- Never open more than one drawer at a time.
- The use of tip-over restraints may reduce but not eliminate the risk of tip-over.

HODEDAH®

- Never open more than one drawer at a time.
- The use of tip-over restranits may reduce but not eliminate the risk of tip-over.

Let's get started...

Helpful hints, read before beginning assembly

- Make sure you receive all boxes. If your item is packed in one box, box count will read 1 of 1, likewise if your item is packed in two boxes, box count will read 1 of 2 and second box will read 2 of 2.
- Read each step carefully. It is very important that each step is performed in the correct order. If these steps are not followed in sequence, assembly difficulties will occur.
- Work in a spacious level area, preferably carpet, near the place the unit will be used.
- **DO NO USE** power tools to assemble your furniture, it will strip and damage parts.
- Your package should include the following hardware and parts. Parts are labeled or stamped on the raw edge. Please inspect contents to ensure you have received all components. **If you are missing any hardware or parts please contact customer service right away before assembly.**

Assembly Tools Required (not supplied)

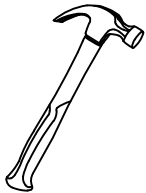

Hammer

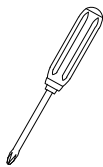

Phillips Screwdriver

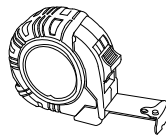

Tape Measure

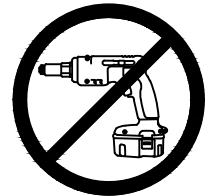







No Power Tools Needed

Product Care and Maintenance

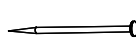
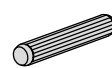
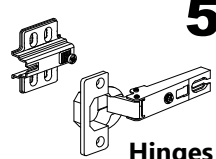
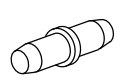
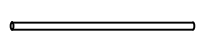
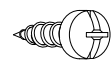
- Wipe clean with dry soft cloth, never use chemicals or cleaning products they will damage the finish.
- Avoid placing your furniture in direct sunlight, as sunlight causes fading.
- Never push, drag or pull your furniture, to move to a new location carefully with two or more people carry the unit to its new location.
- Avoid extreme changes in temperature by arranging furniture away from radiators, heat and air vents and air conditioning units.

Hardware List

1  Screw M6 x 40mm	QTY <input type="checkbox"/> 18 Pcs	2  Screw M3.5 x 14mm *For # 5 HINGERS	QTY <input type="checkbox"/> 28 Pcs	3  Nail	QTY <input type="checkbox"/> 35 Pcs	4  Pvc Dowel	QTY <input type="checkbox"/> 29 Pcs
5  Hinges	QTY <input type="checkbox"/> 6 Sets	6  Shelf Support	QTY <input type="checkbox"/> 12 Pcs	7  Hanging Rod	QTY <input type="checkbox"/> 1 Pc	8  Screw M 10 X 1/2 MM	QTY <input type="checkbox"/> 12 Pcs
10  Allen Key	QTY <input type="checkbox"/> 1 Pc	11  V-Bracket	QTY <input type="checkbox"/> 2 Pcs	12  Screw M6 x 50mm	QTY <input type="checkbox"/> 4 Pcs	13  Pvc Cap	QTY <input type="checkbox"/> 22 Pcs
14 Anti-Tip Kit (separate from hardware pack)	QTY <input type="checkbox"/> 1 PK						

Accessories

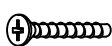
9  Handle	QTY <input type="checkbox"/> 2 Pcs
 Screw M4 X 20mm	<input type="checkbox"/> 4 Pcs

Important

1. Before you throw the package, please use the Check Box to identify the parts and hardware to ensure that you have everything you need.
2. Check and measure the bolts before applying them to parts.
3. Do not completely tighten all hardware until the entire assembly is complete, unless indicated otherwise.

Parts List

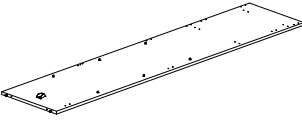
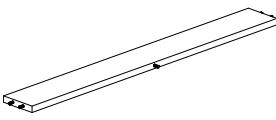
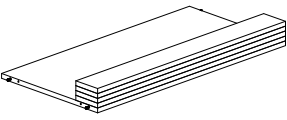
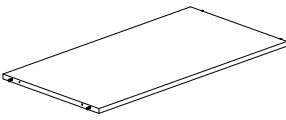
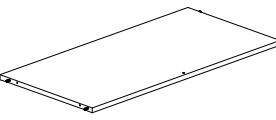
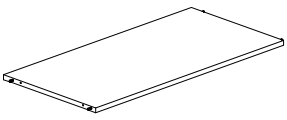
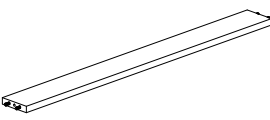
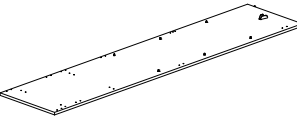
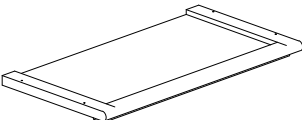
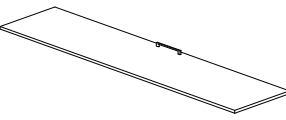
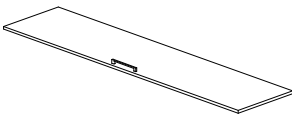
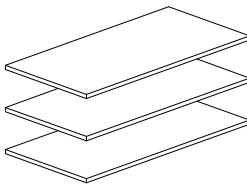
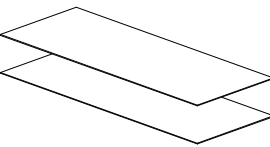
<p>A Left Side Panel 1791 x 394 x 15mm</p> 	<p>QTY</p> <p>1 Pc</p>	<p>B Kick Panels 768 x 89 x 15mm</p> 	<p>QTY</p> <p>1 Pc</p>	<p>C Kick Panel (Back) & Back Strengthening Panel 768 x 394 x 75mm</p> 	<p>QTY</p> <p>1 Pc</p>
<p>D Kick Panel (Back) & Back Strengthening Panel 768 x 394 x 15mm</p> 	<p>QTY</p> <p>1 Pc</p>	<p>E Bottom Panel 768 x 377 x 15mm</p> 	<p>QTY</p> <p>1 Pc</p>	<p>F Partition Panel 768 x 377 x 15mm</p> 	<p>QTY</p> <p>1 Pc</p>
<p>G Back Strengthening Panel 768 x 76 x 15mm</p> 	<p>QTY</p> <p>1 Pc</p>	<p>H Right Side Panel 1791 x 394 x 15mm</p> 	<p>QTY</p> <p>3 Pcs</p>	<p>I Top Panel 803 x 425 x 30mm</p> 	<p>QTY</p> <p>2 Pcs</p>
<p>J Left Door 1697 x 395 x 15mm</p> 	<p>QTY</p> <p>1 Pc</p>	<p>K Right Door 1697 x 395 x 15mm</p> 	<p>QTY</p> <p>1 Pc</p>	<p>L Adjust Panel 768 x 381 x 15mm</p> 	<p>QTY</p> <p>2 Pcs</p>
<p>M Back Panels 1030 x 397 x 3mm</p> 	<p>QTY</p> <p>1 Pc</p>				

HODEDAH®

The Breakdown

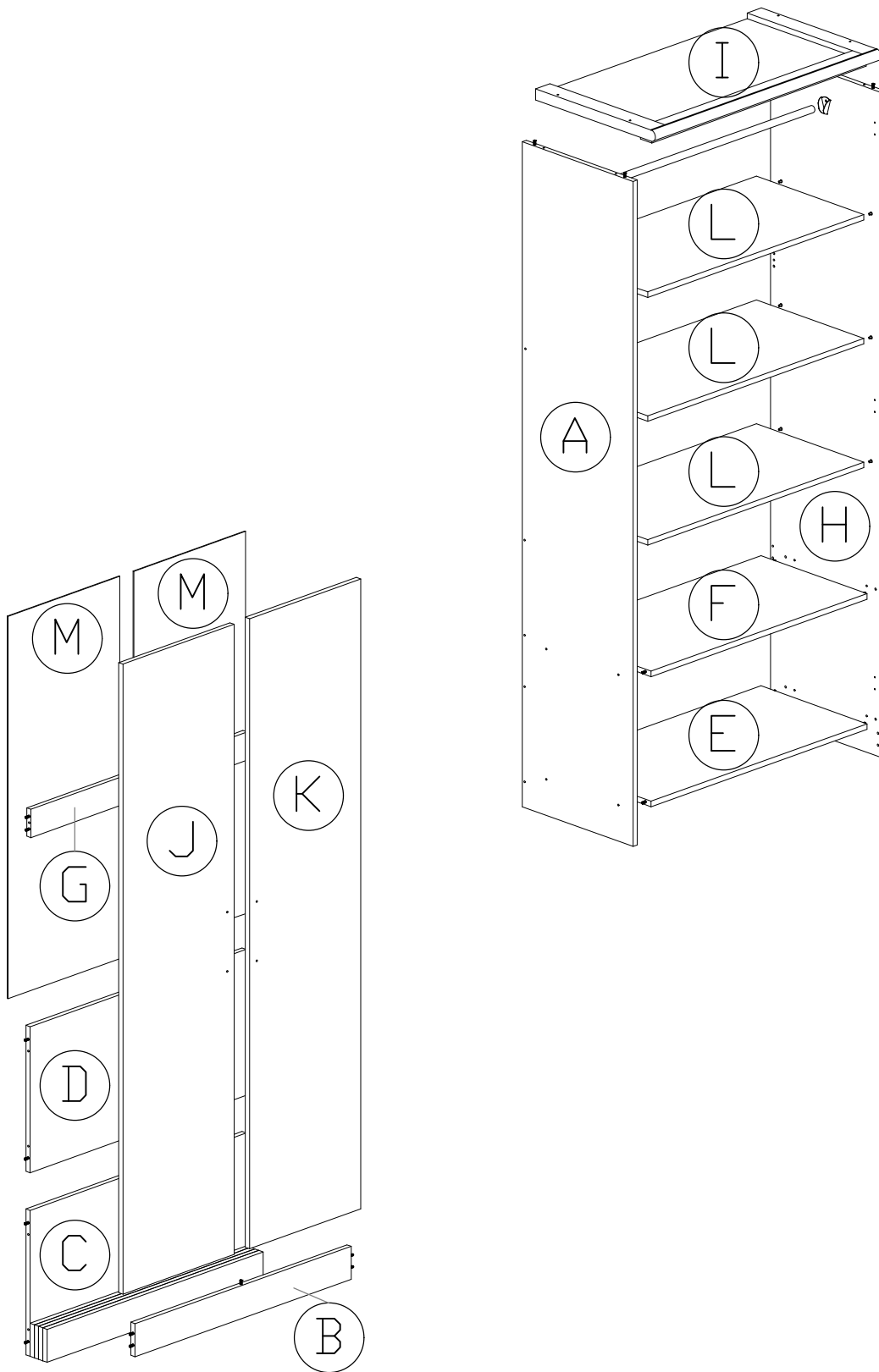

Pre - Assembly

1. Insert the PVC dowels ④ on top of panel A and H using hammer to gently tap them in.

2. Fasten V-Bracket ⑪ onto panel A and H by using 2 screws ②.

3. Insert 6 shelf supports ⑥ onto panel A and H.

4. Place hinges ⑤ on panel A and H. Then fasten them with 2 screws ② and 2 screws ⑧.

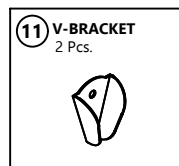
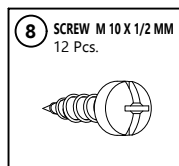
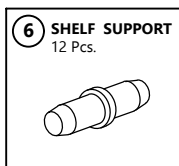
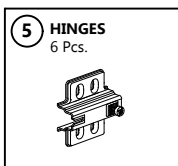
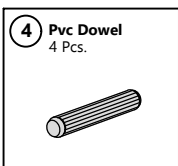
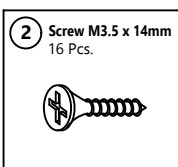
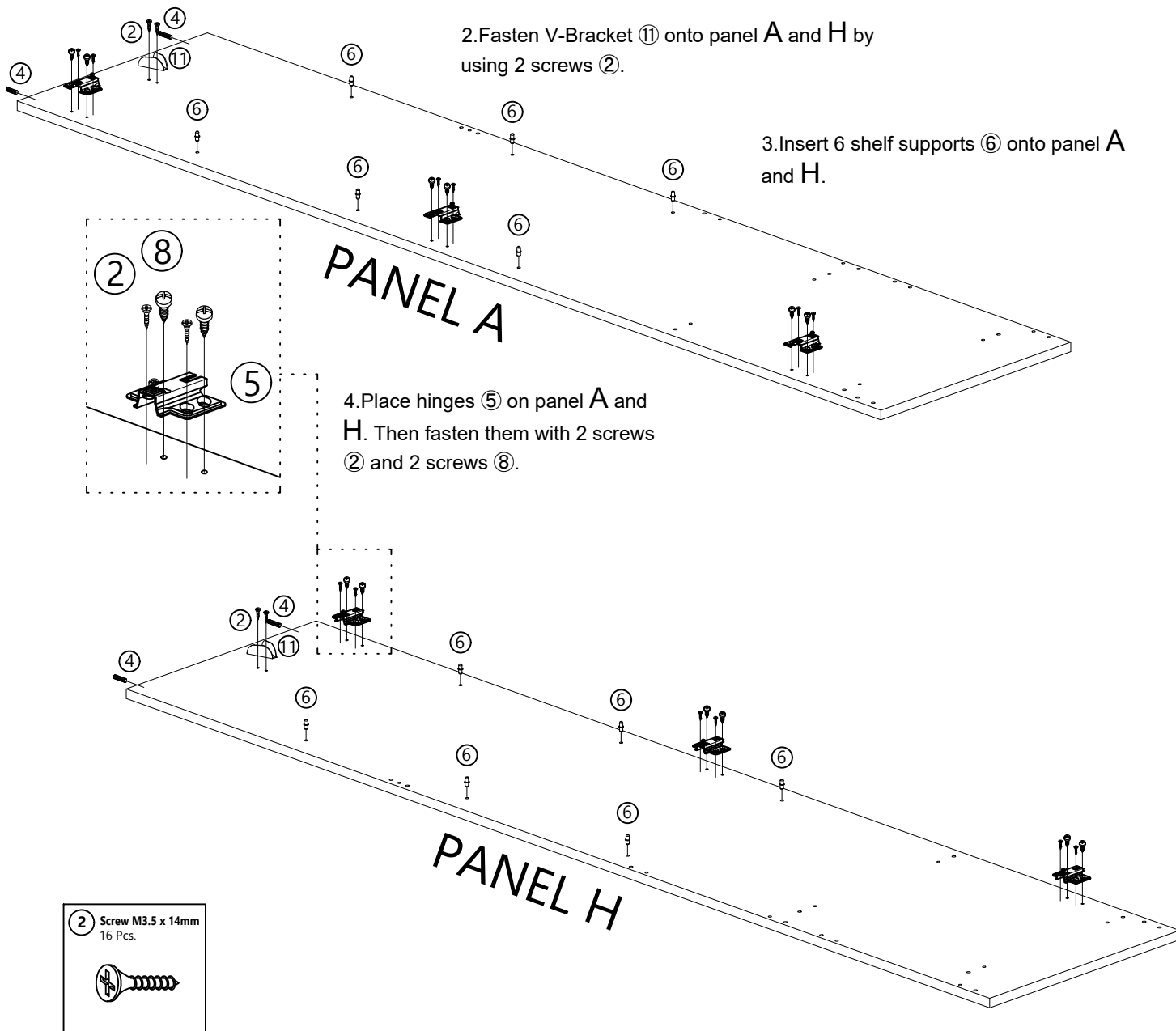

HODEDAH®

Pre - Assembly

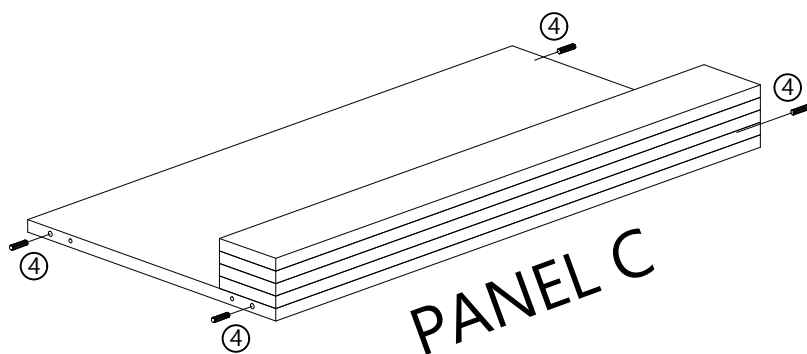
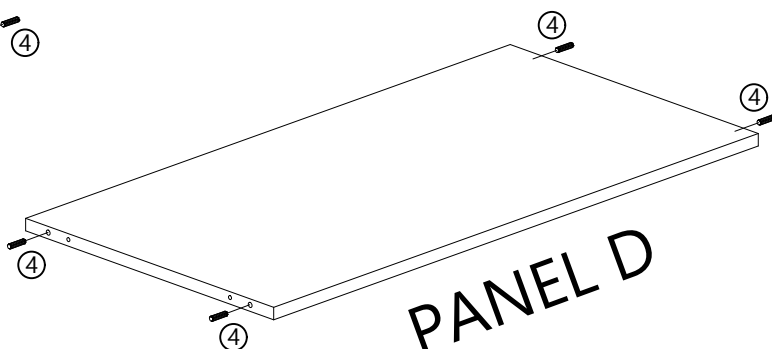
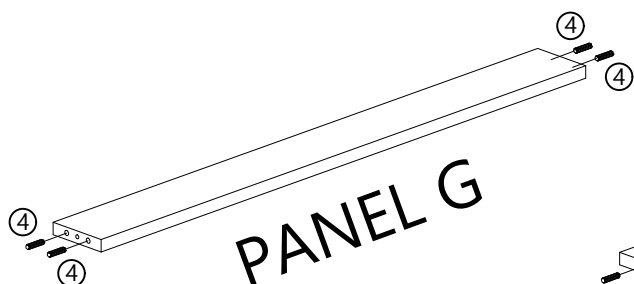

Insert dowels ④ to panel B, C, D, E, F and G using hammer to gently tap them in.

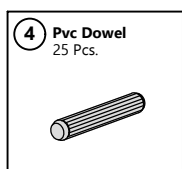
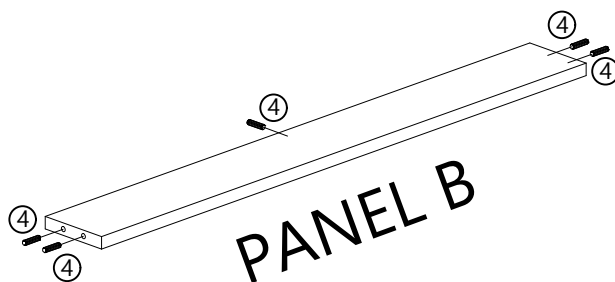
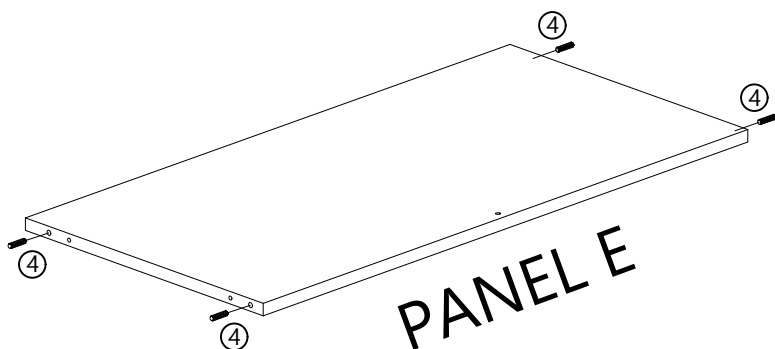
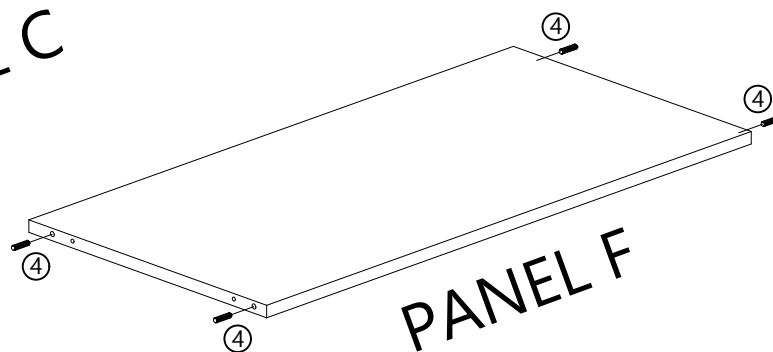

HODEDAH®

Door Panel Assembly

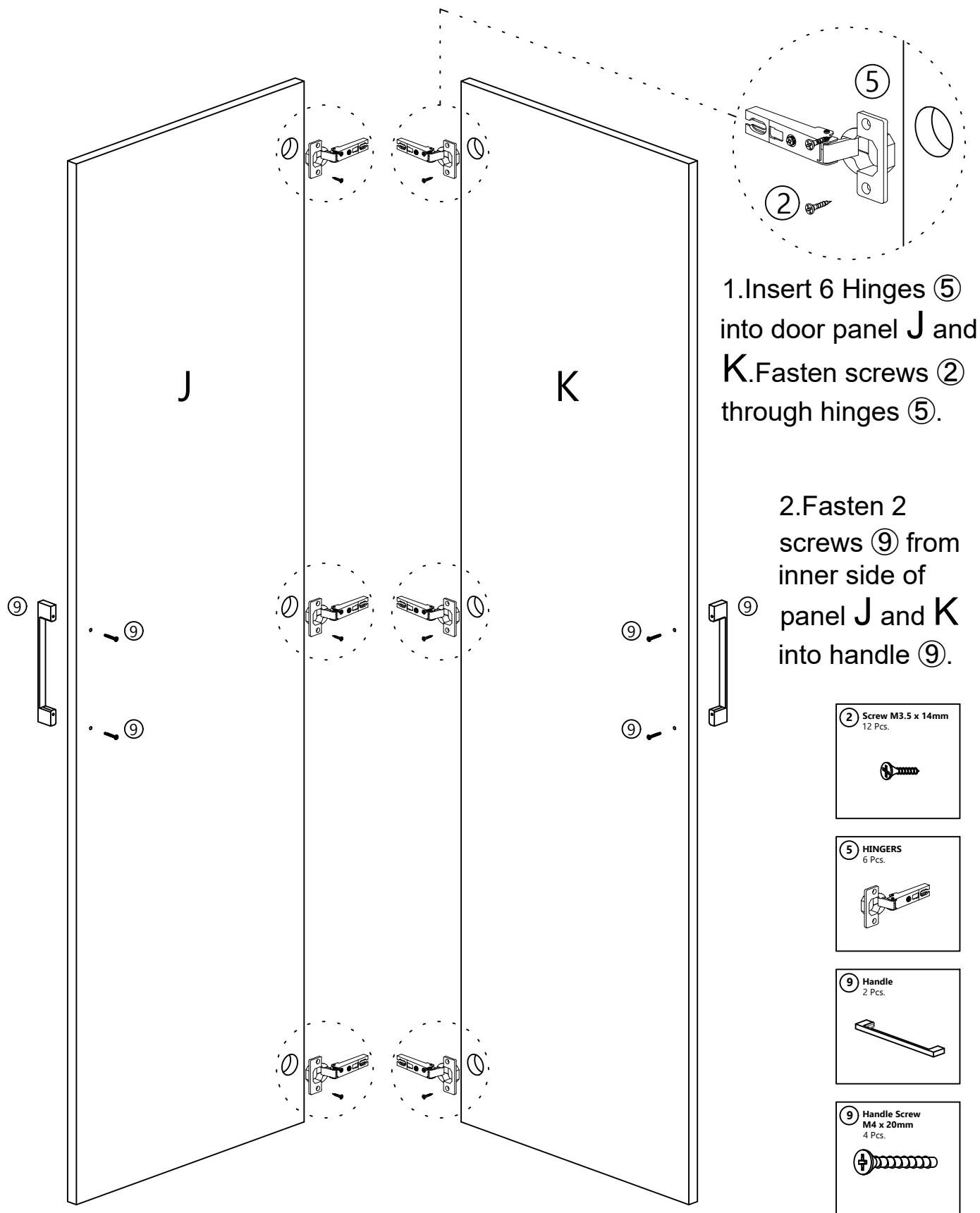

HODEDAH®

Step 1

1. Place panel **B** onto panel **E** by inserting panel **B**'s dowels into panel **E**'s non-thru holes.

2. Place panel **B, C, D, E, F** and **G** onto left side panel **A** by inserting the dowels onto left side panel **A**'s non-thru holes.

3. Use allen key ⑩ to fasten screws ① from thru holes of left side panel **A**.

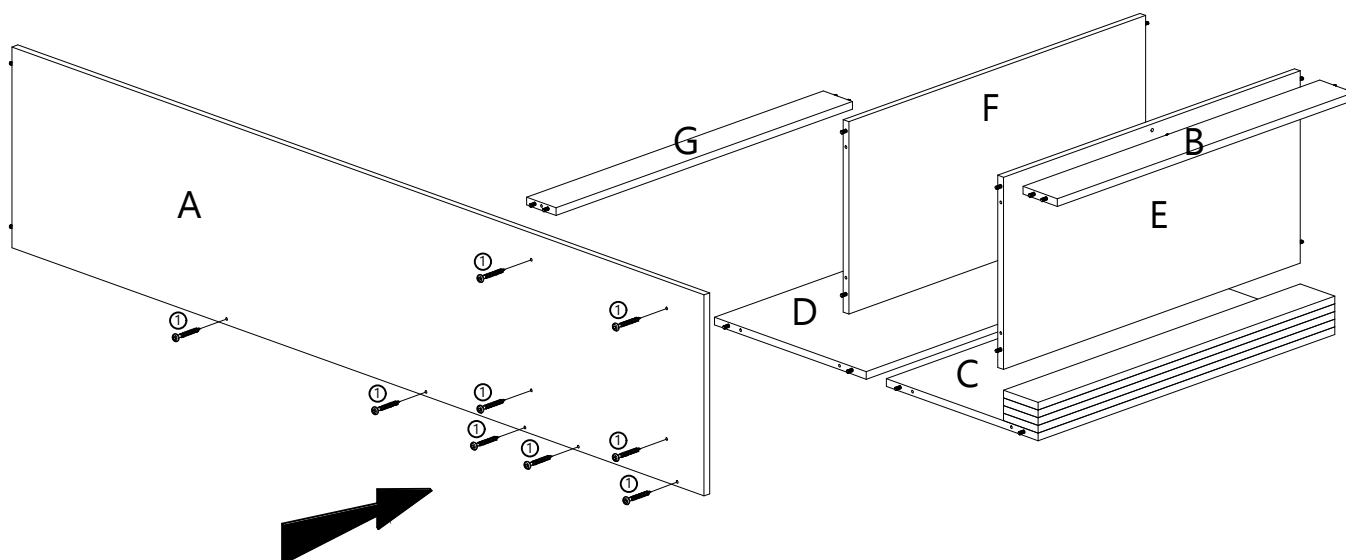
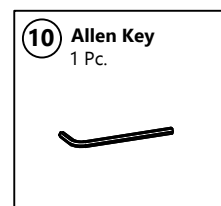
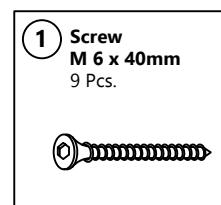

HODEDAH®

Step 2

1. Place panel B,C,D,E,F and G onto right side panel H by inserting the dowels onto right side of panel H's non-thru holes.

2. Use allen key ⑩ to fasten screws ① from thru holes of right side panel H.

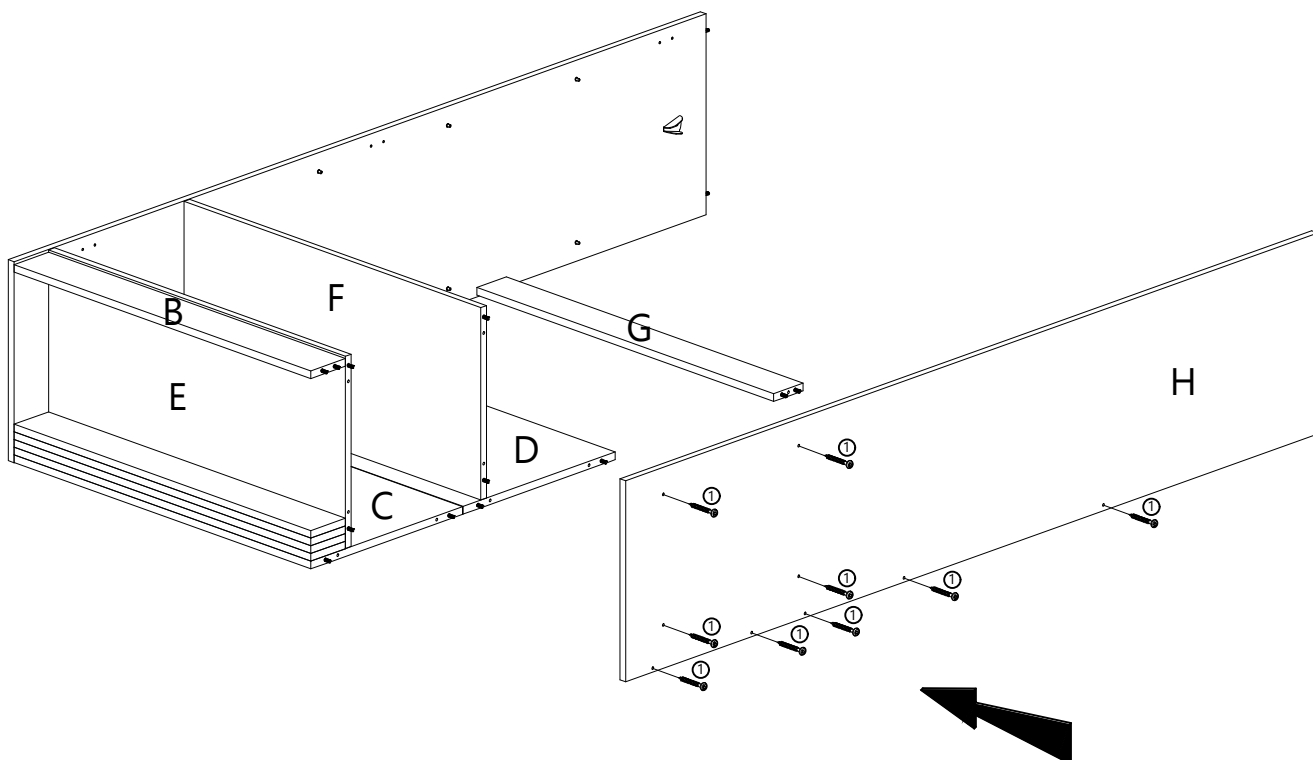
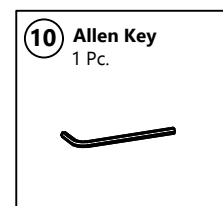
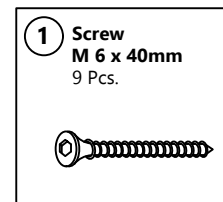

HODEDAH®

Step 3

1. Place panel I onto Panel A and H by inserting panel A and H's dowels into panel I's non-thru holes and align properly.

2. Use allen key ⑩ to fasten screws ⑪ onto panel I.

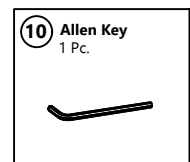
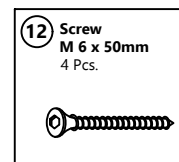
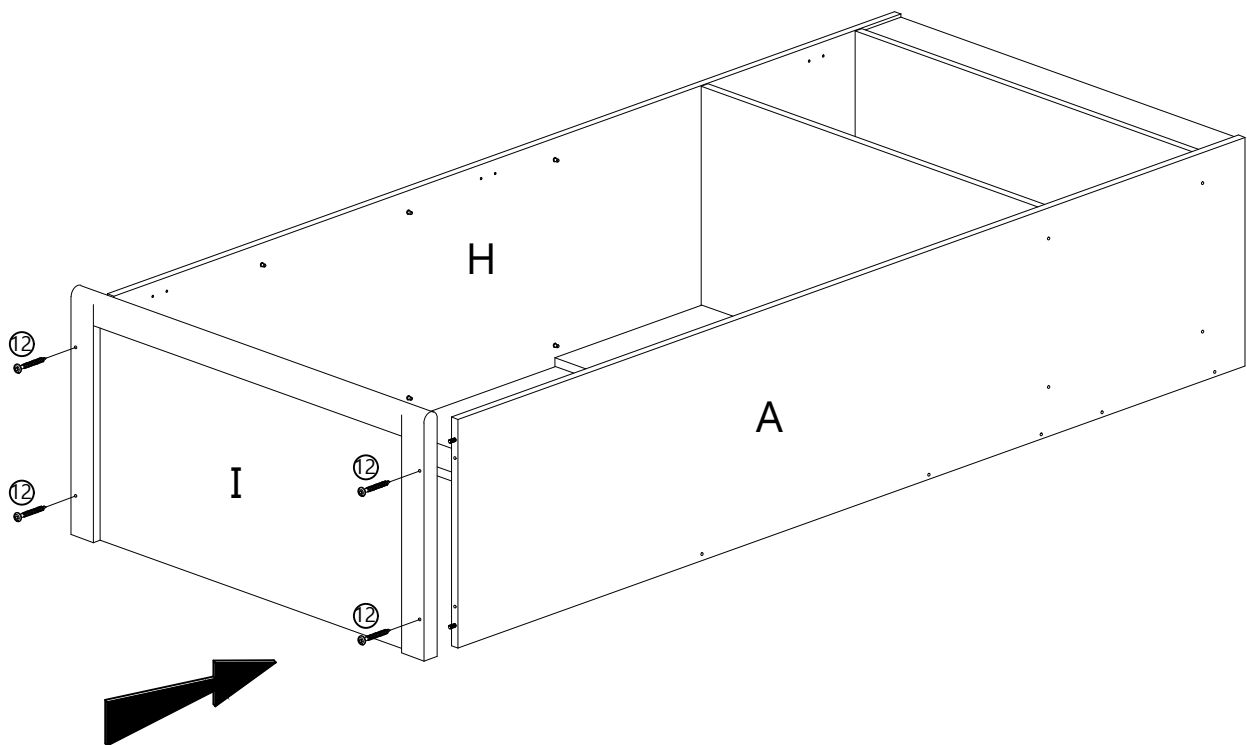

Step 4

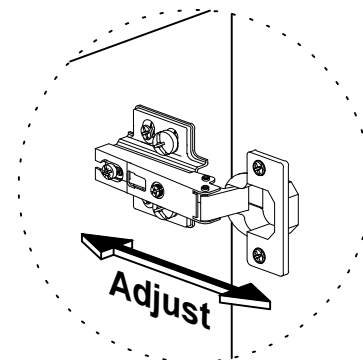
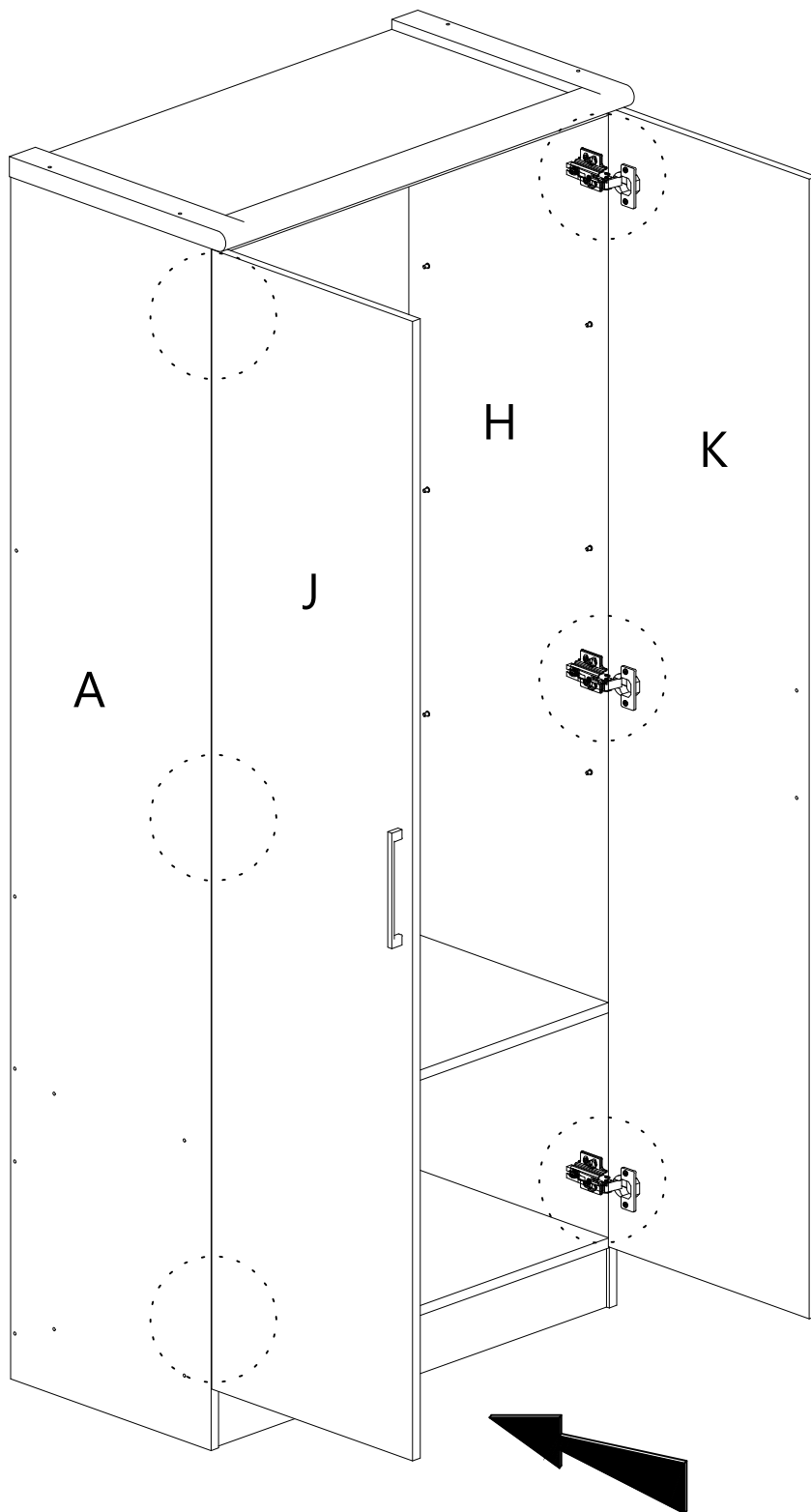

Insert hinges on panel J and K into panel A and H.

You can adjust the door panels by fastening and loosening the screws.



HODEDAH®

Step 5

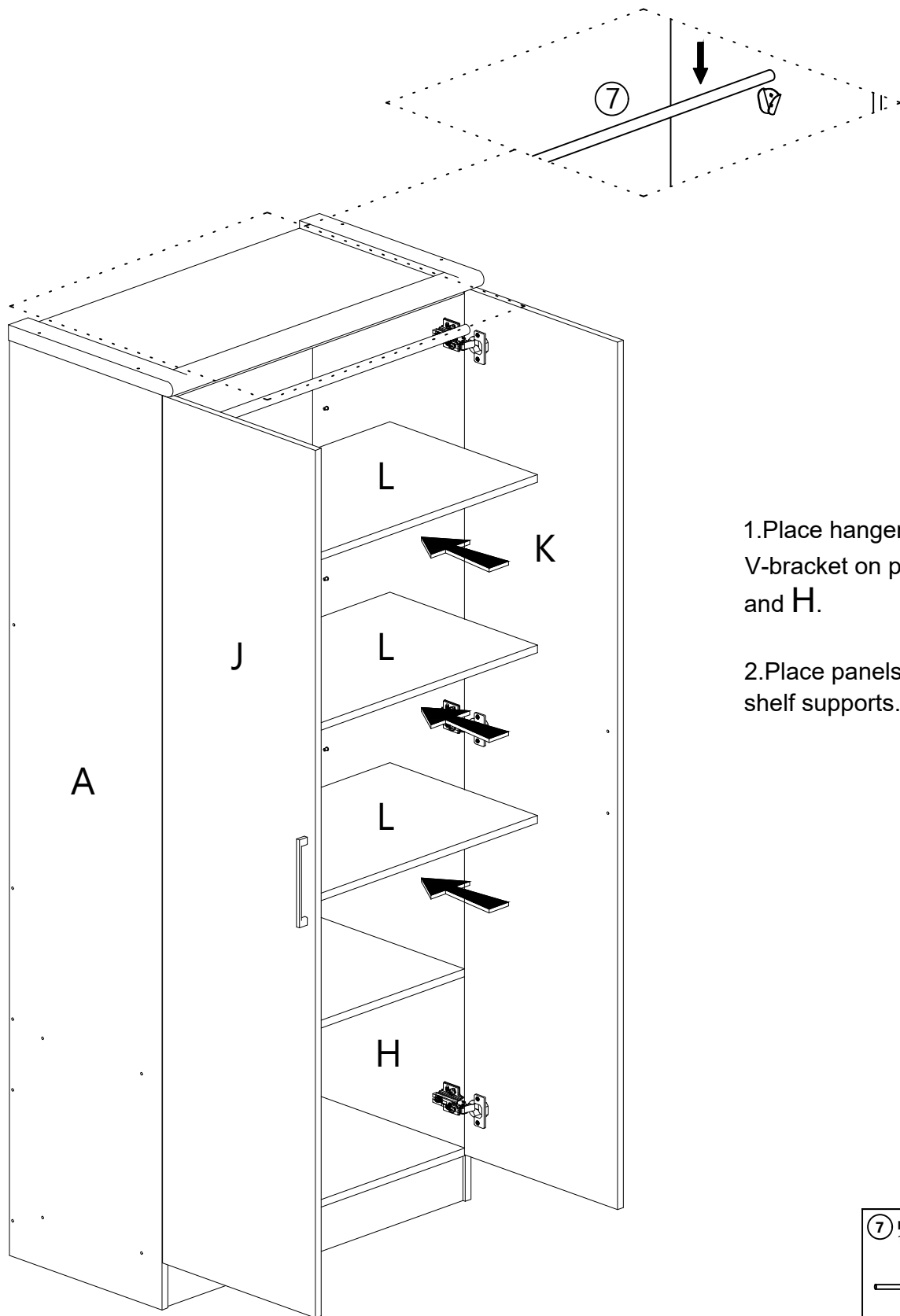

1. Place hanger onto V-bracket on panels **A** and **H**.

2. Place panels **L** onto shelf supports.

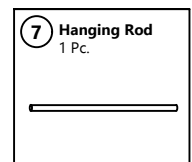

Step 6

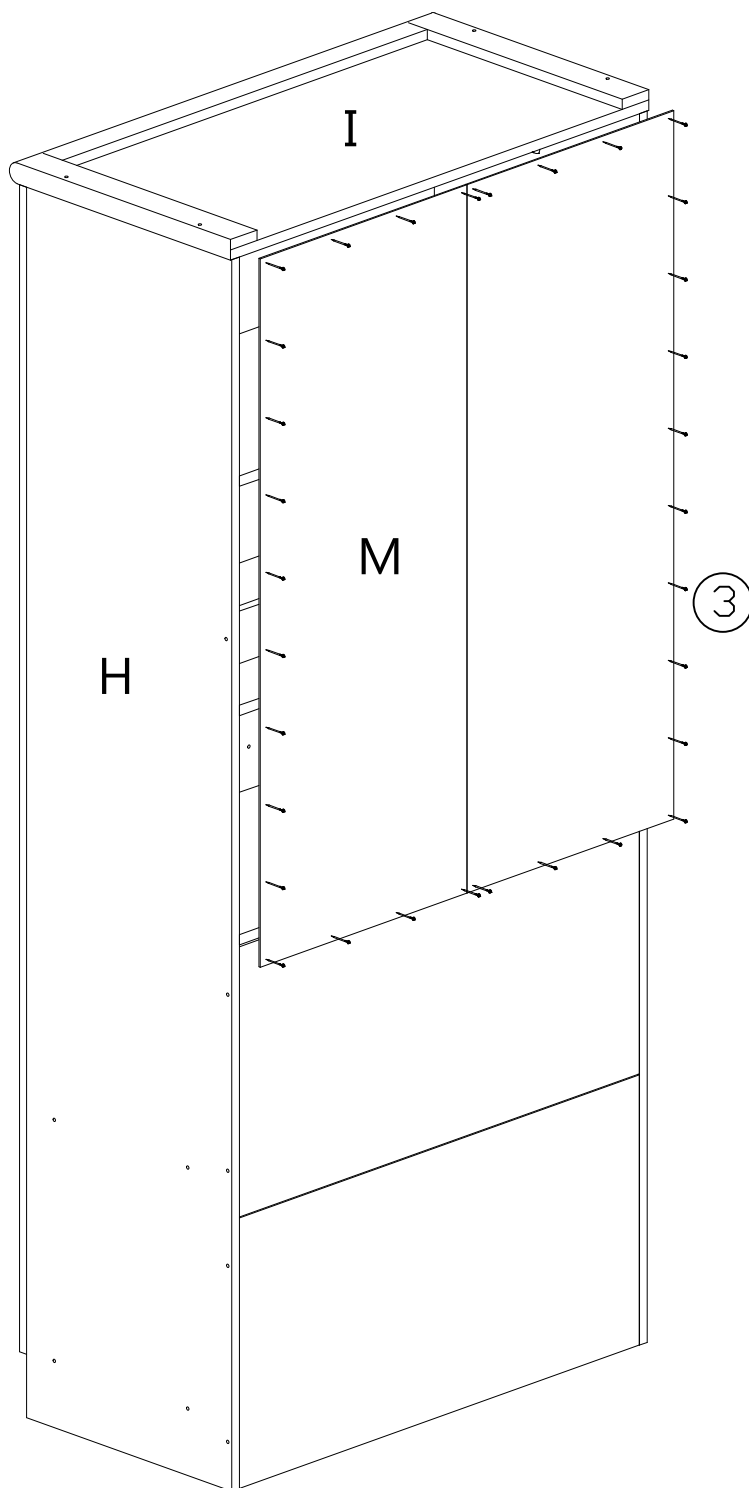

1. Place panels M onto the back of main unit, then align them properly for nailing.
2. Use hammer to insert the nails at the center of the edges. Gap between nails should be about 100mm.

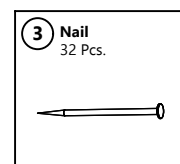

HODEDAH®

Step 7

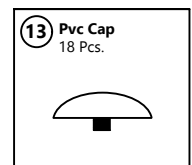
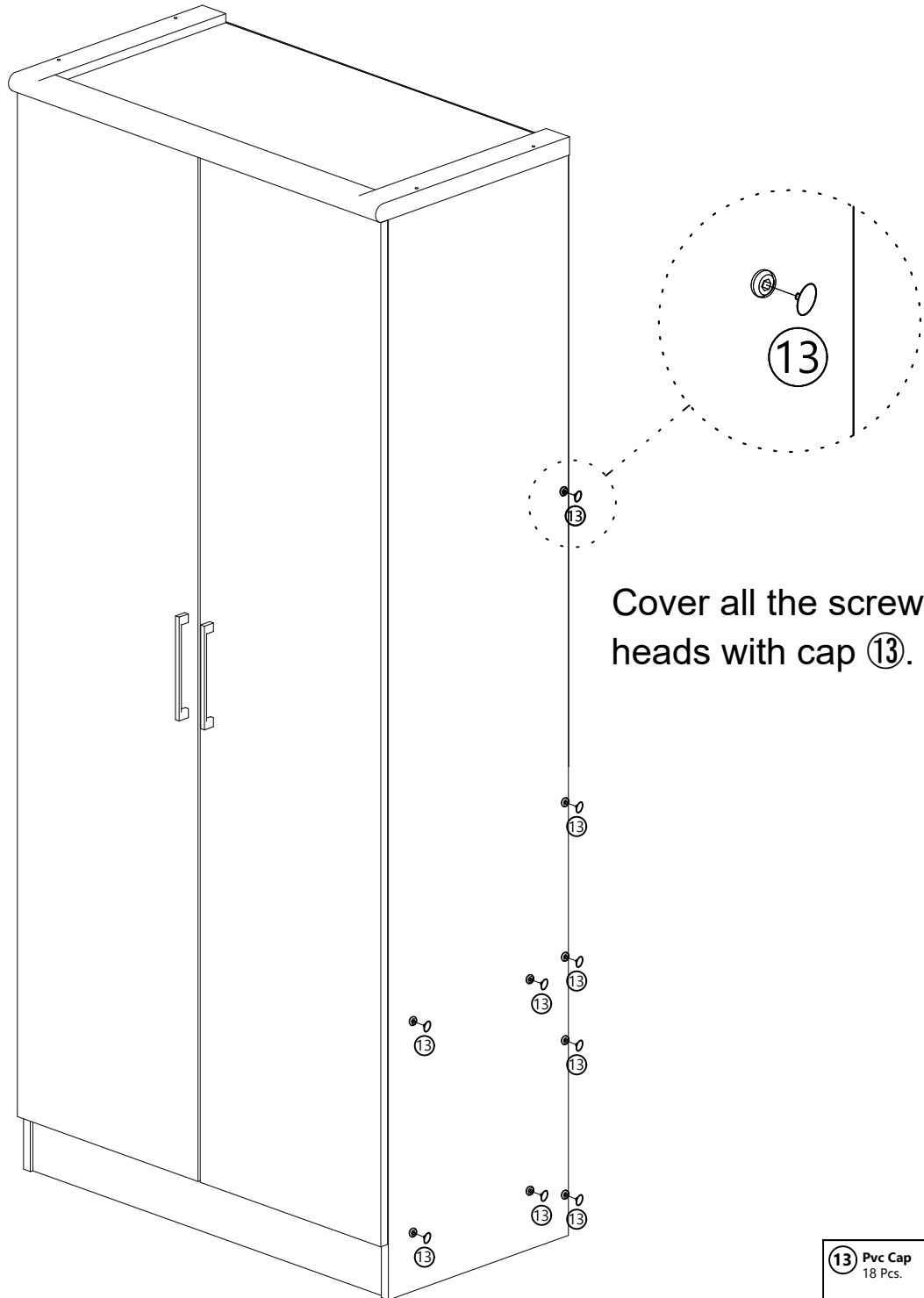

FITTING OF ANTI-TIP SAFETY STRAP

STEP 1:

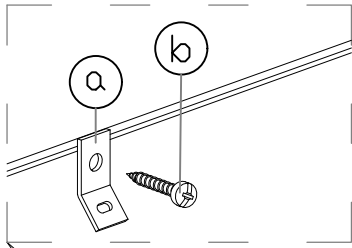

- Attach the mounting bracket (a) to the furniture in the solid part below the top panel a few inches away from the side of the unit.
- Screw (b) through the smallest hole of (a).

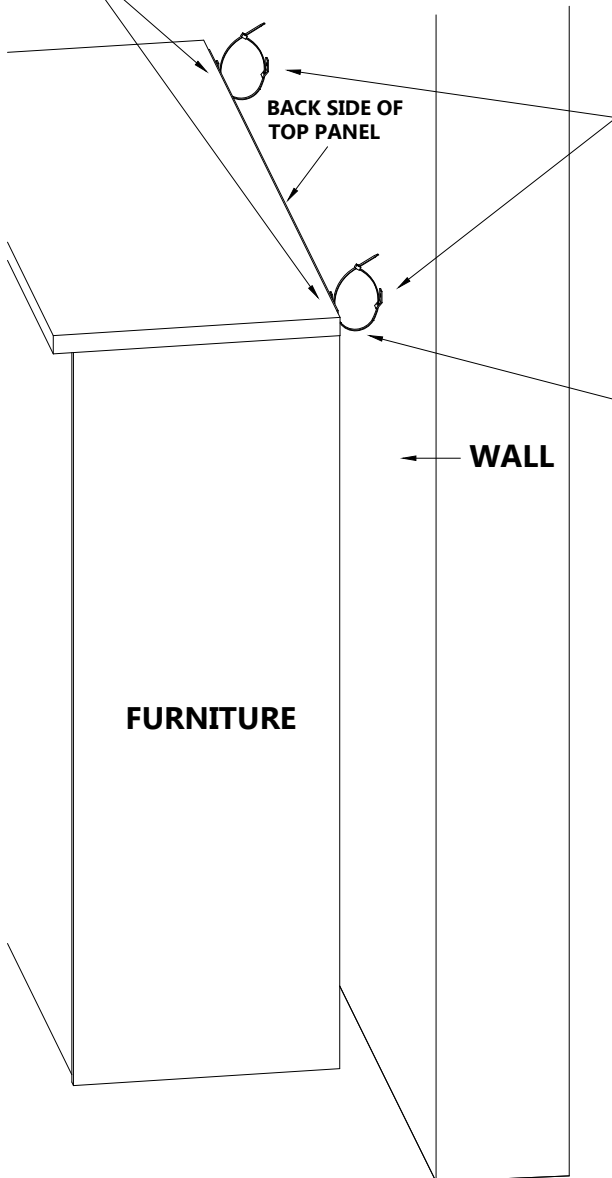

STEP 2:

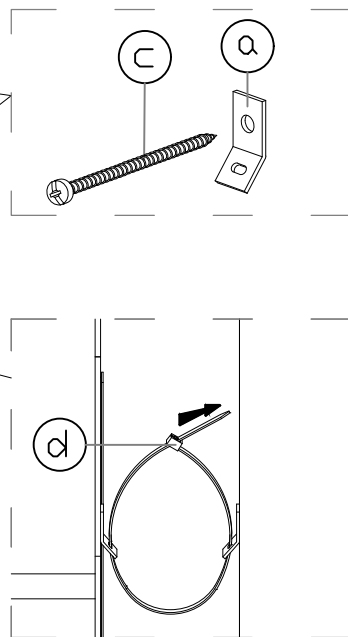

- Locate a stud in the wall behind the unit, does not have to be centered.
- Place the other mounting bracket (a) on the wall stud 2 inches below the mounting bracket secured to the back of your unit.
- Attach to the wall stud using (c) through the smaller hole of (a).

STEP 3:

- Repeat the same step a few inches away from the other side of the unit.
- Place the furniture into position so both mounting brackets are vertically in line.
- Lace the end of the restraint strap through the larger holes in each mounting bracket.
- Secure the straps and lock into place.

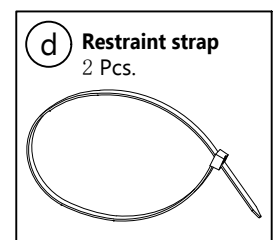
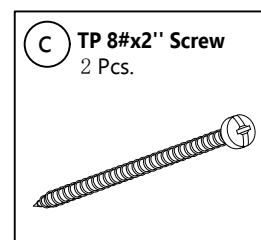
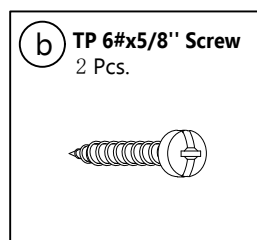
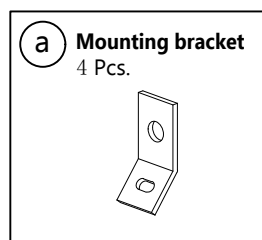

HODEDAH®

Job Complete

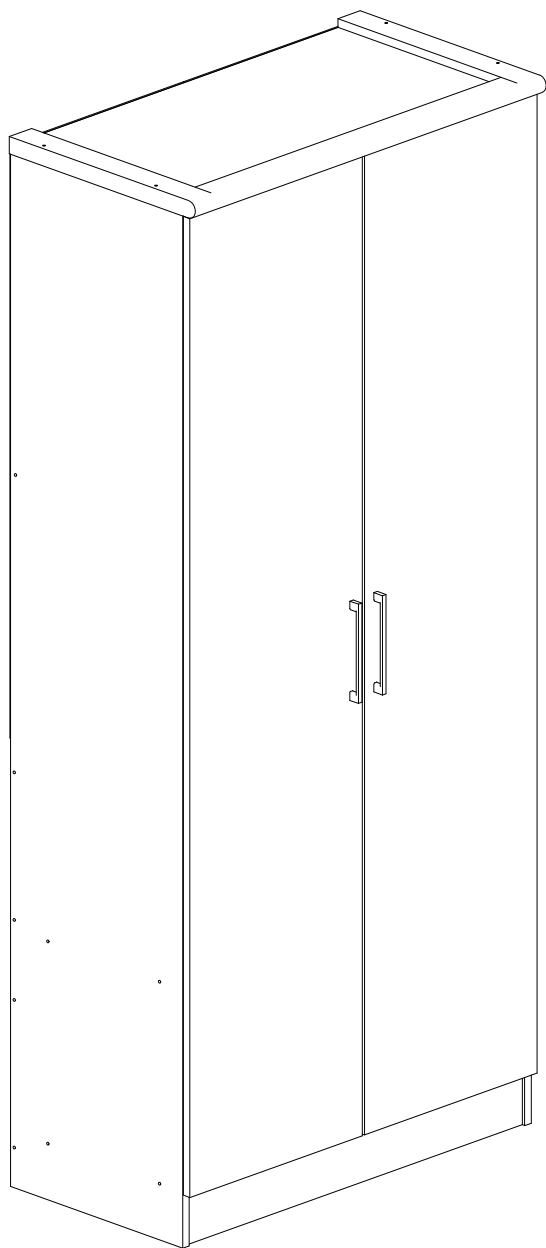

Enjoy & Thank you for purchasing from Hodedah!



In the interest of our environment please dispose of all packaging thoughtfully.