



# ***HODEDAH***

[www.hodedah.com](http://www.hodedah.com)

[support@hodedah.com](mailto:support@hodedah.com)

## ***ASSEMBLY INSTRUCTIONS***

### ***GLASS COFFEE TABLE***

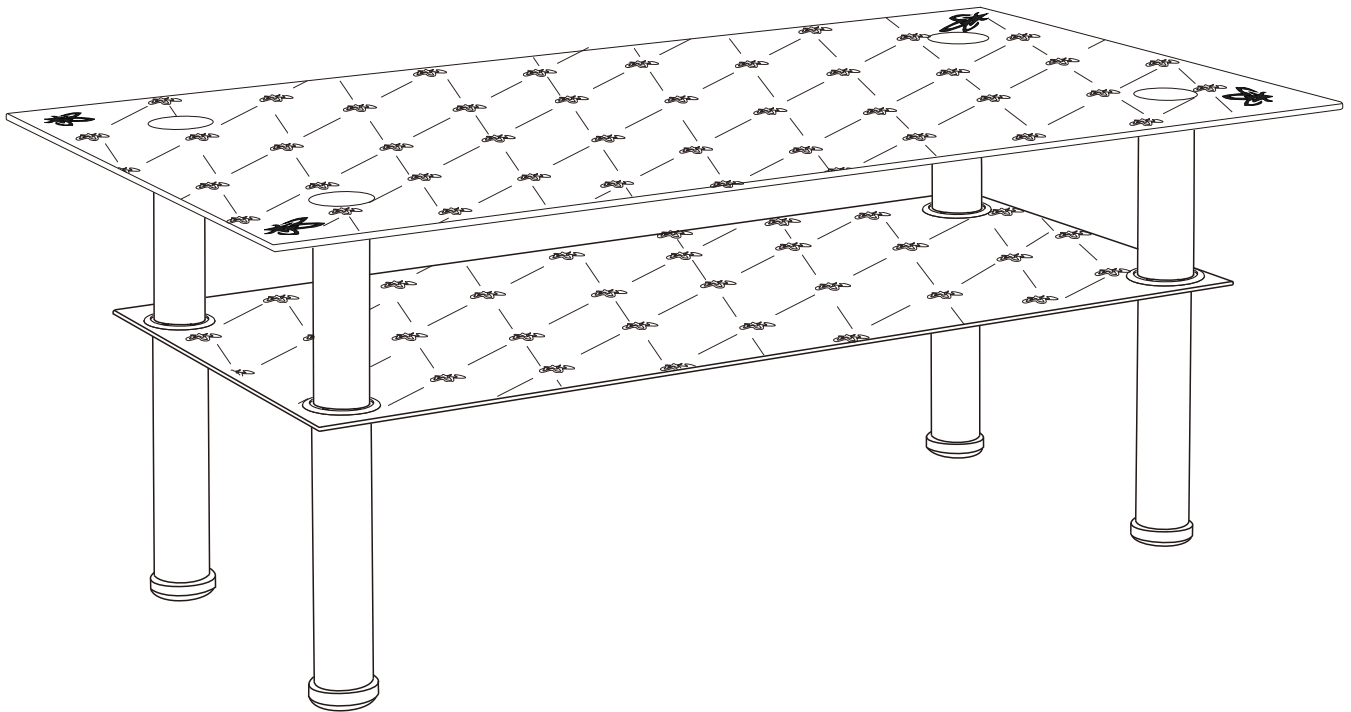

### ***HICT22***

*H17.7"W39.4"D19.7"*



# HODEDAH

[www.hodedah.com](http://www.hodedah.com)

[support@hodedah.com](mailto:support@hodedah.com)



## IMPORTANT NOTE:

- *This product contains small components, please ensure that they are kept away from small children.*
- *This instruction booklet contains **IMPORTANT** safety information. Please read and keep for future reference.*
- *Note: you will find extra screws and bolts in hardware pack in case of any missing pieces.*
- *If the glass is chipped or broken, do not attempt to assemble the item.*

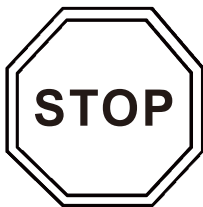

**DO NOT RETURN PRODUCT TO THE STORE**

*If a part is missing or damaged, email our customer service. We will gladly ship your replacement parts **FREE** of charge.*

**Need Parts or Assistance?**

*Email us at*

[support@hodedah.com](mailto:support@hodedah.com)

*For prompt, reliable service, please have your assembly manual ready.*



# HODEDAH

[www.hodedah.com](http://www.hodedah.com)  
[support@hodedah.com](mailto:support@hodedah.com)

**Thank you for purchasing from Hodedah**

**To learn more about hodedah and our products visit  
[www.hodedah.com](http://www.hodedah.com)**

## **READ BEFORE BEGINING ASSEMBLY**

- Read each step carefully. It is very important that each step of instruction is performed in the correct order. If these steps are not followed in sequence, assembly difficulties will occur.
- Make sure all parts are included. Most parts are labeled or stamped on the raw edge.
- Work in spaclous area, preferably on a carpet, near the place the unit will be used.
- Do not use power tools assemble your furniture. Power tools may strip or damage the parts.

## **HELPFUL HINTS**

- Call us if you need assistance.
- Move your new furniture carefully, with two people lift and carry the nuit to it's new location.
- Never push, drag or pull your furniture(especially on carpet).

## **Warranty Information**

*Hodedah warrants this product to be free from defects in material and workmanship agrees to remedy any such defect. This warranty covers one year from the date of original purchase. This is solely limited to be repair or replacement of defective parts and no assembly labor is included.*

*This warranty does not apply to any products which has been improperly assembled, subjected to misuse or abuse or which has been altered or repaired in any way.*

*To obtain warranty service, purchaser must present original bill of sale. Components repaired or replaced warranted through the remainder of the original warranty period only. The defective components will be repaired or replaced without charge, subject to the terms and conditions described above.*

**For help with assembly, Identifying parts, product information  
or to order parts, please contact us:**

Call us at:  
718-456-0505  
Monday-Friday  
9:00 am-5:00 pm

Visit our website:  
[www.hodedah.com](http://www.hodedah.com)



# HODEDAH







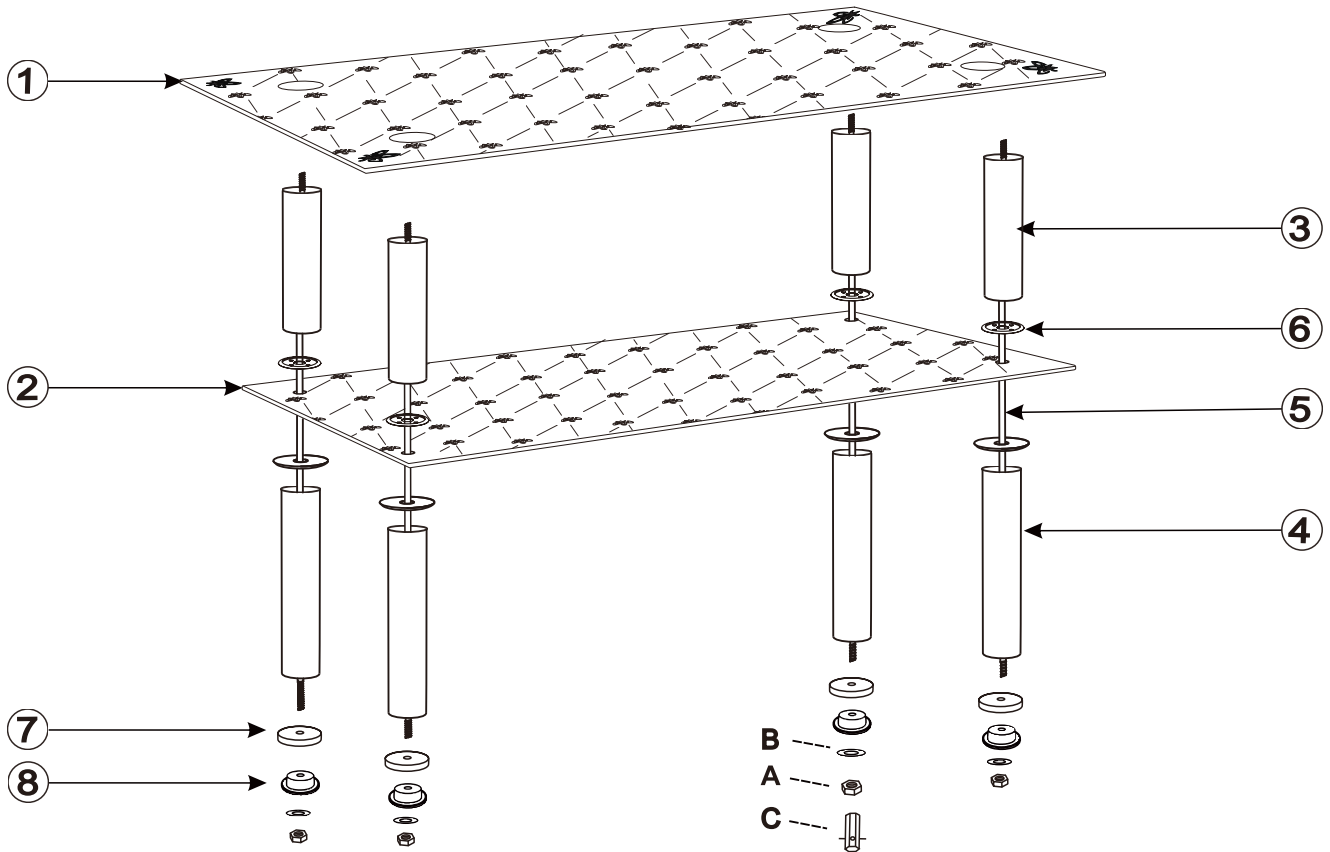

[www.hodedah.com](http://www.hodedah.com)

[support@hodedah.com](mailto:support@hodedah.com)



## Breakdown Structure

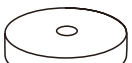

## Parts

<b>1</b> Upper Glass 1 un.  1000*500mm	<b>2</b> Layer Glass 1 un.  800*400mm	<b>3</b> Stainless tube 4 un.  Ø50*200mm
<b>4</b> Stainless tube 4 un.  Ø50*220mm	<b>5</b> Screw Rod 4 un.  Ø8*420mm	<b>6</b> Plastic Washer 8 un.  Ø55mm
<b>7</b> Steel Footing 4 un.  Ø60*12mm	<b>8</b> Rubber Mat 4 un.  Ø58*18mm	

## Hardware

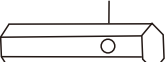
<b>A</b> Flat Nut 4 un.  Ø8mm	<b>B</b> Steel Washer 4 un.  Ø8mm
<b>C</b> Wrench 1 un.  Ø15*50mm	



# HODEDAH

[www.hodedah.com](http://www.hodedah.com)  
[support@hodedah.com](mailto:support@hodedah.com)

## Step 1

- Put upper glass(1) on clear floor or carpet, aluminum tray side upwards.
- Attach screw rod (5) on aluminum trays.

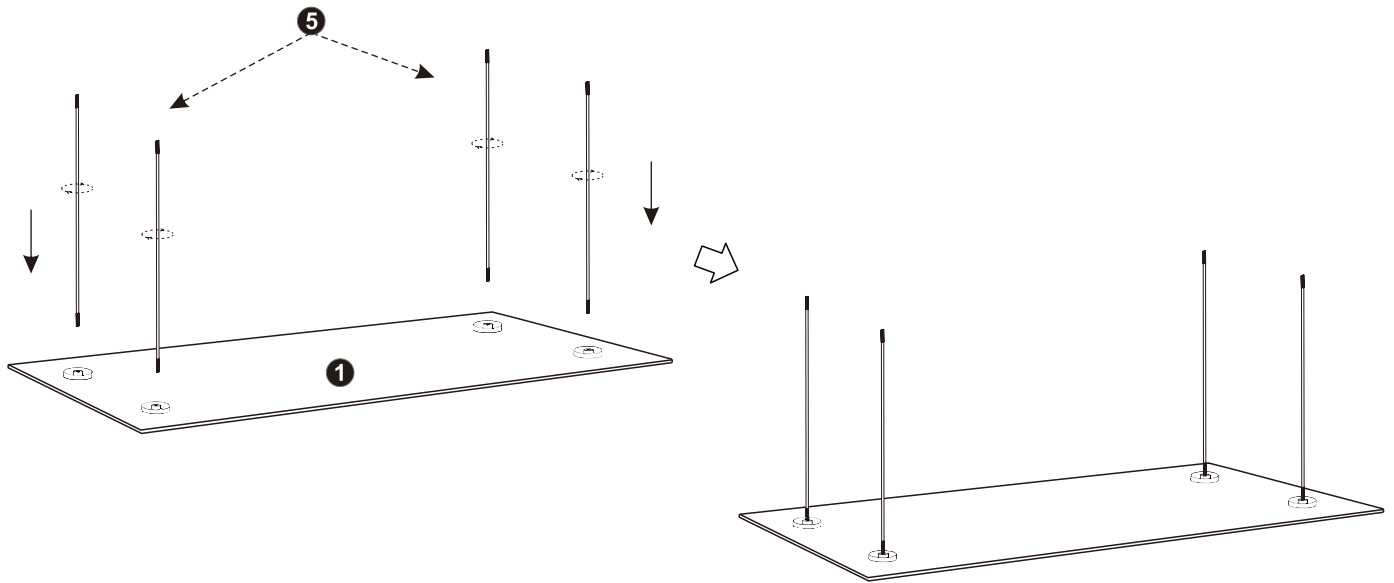

## Step 2

- Insert stainless tube (3) through screw rod(5).

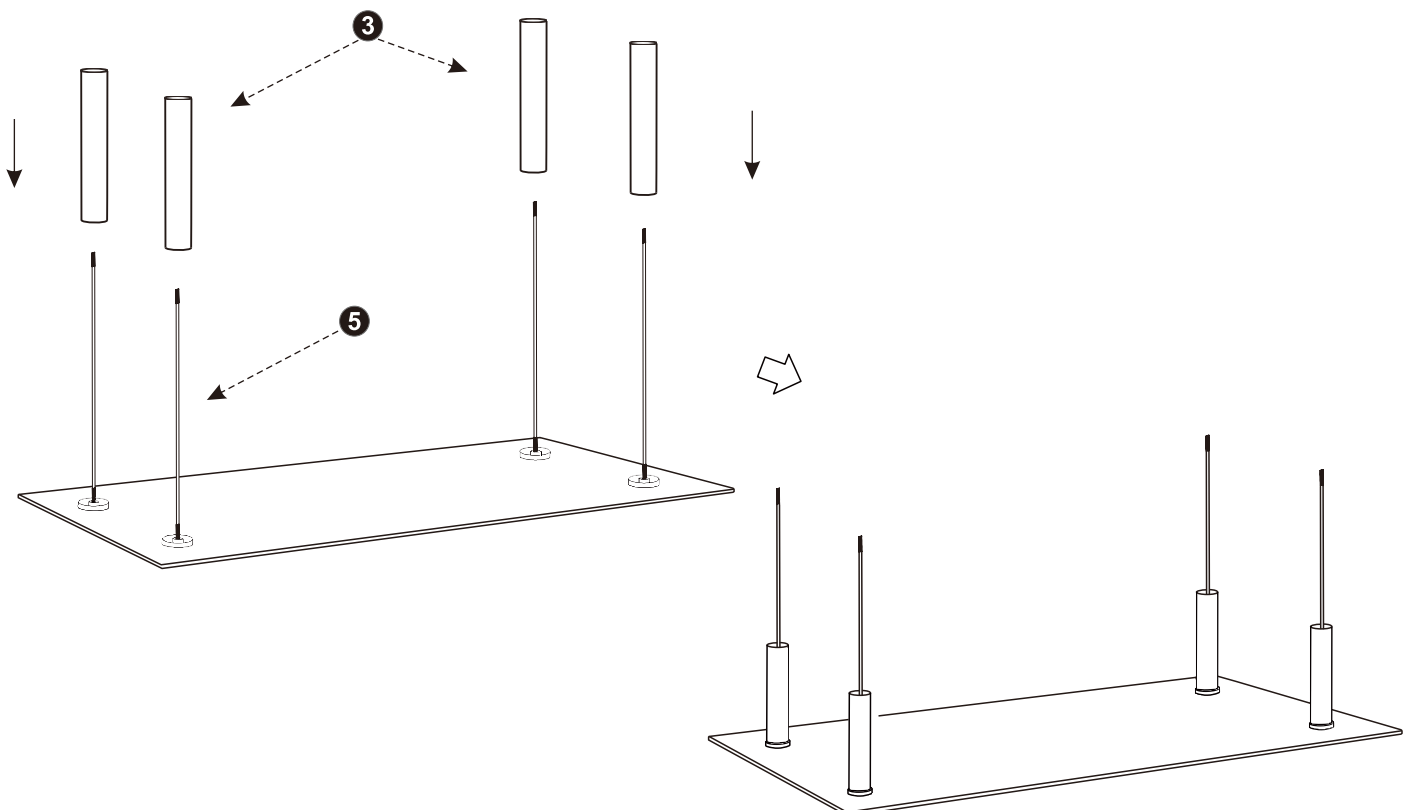



# HODEDAH

[www.hodedah.com](http://www.hodedah.com)  
[support@hodedah.com](mailto:support@hodedah.com)

## Step 3

- Insert plastic washer (6) through screw rod(5).

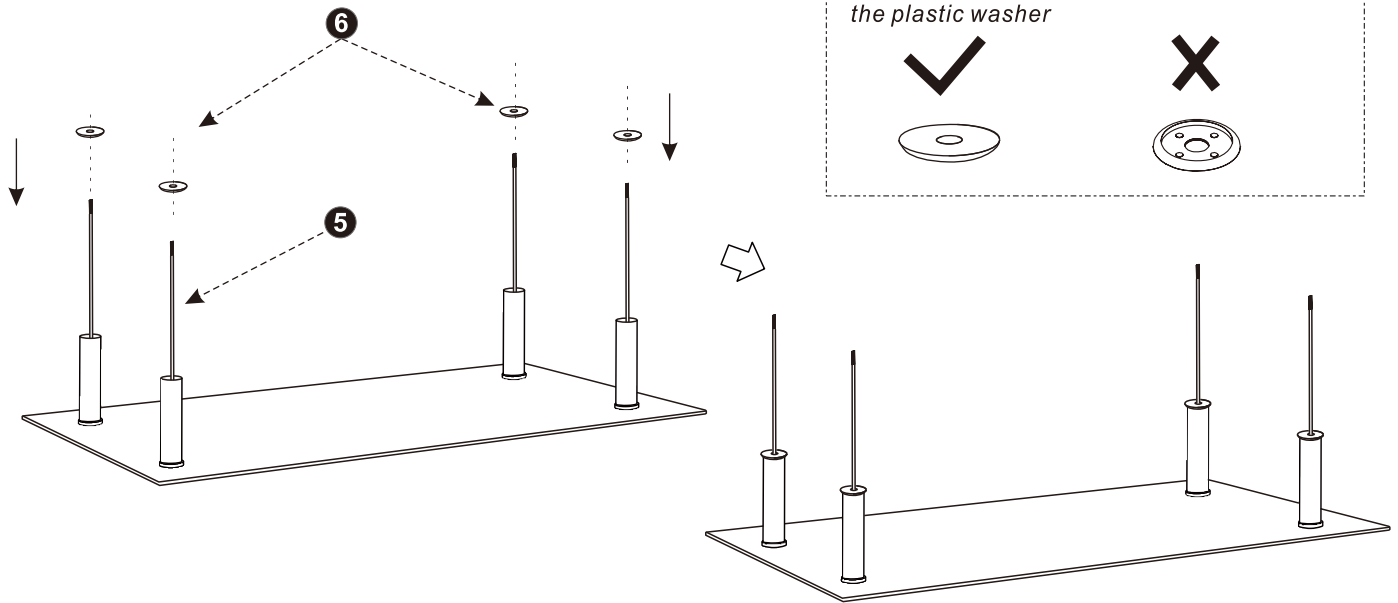

## Step 4

- Put layer glass (2) through screw rod(5), painting side upwards.

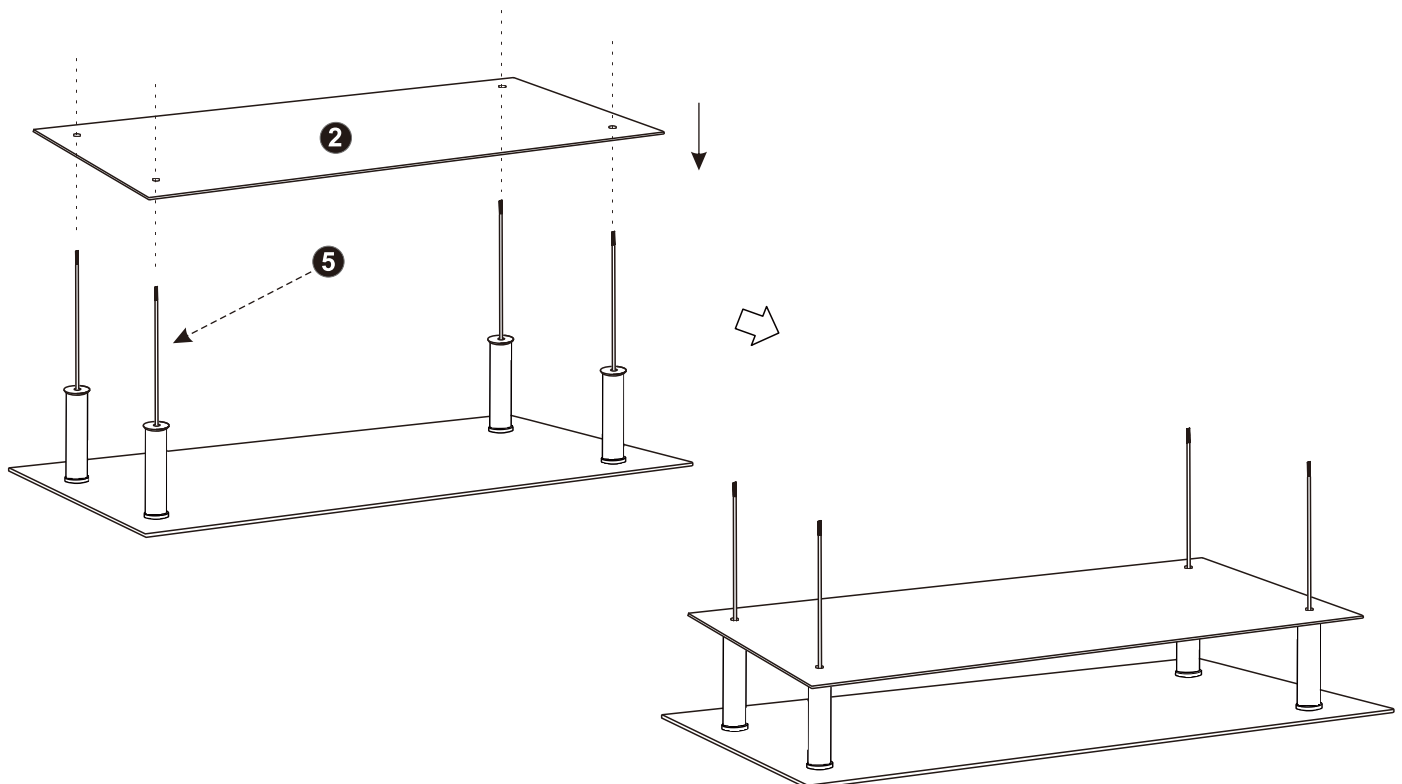



# HODEDAH

[www.hodedah.com](http://www.hodedah.com)

[support@hodedah.com](mailto:support@hodedah.com)

## Step 5

• Insert plastic washer (6) through screw rod(5).

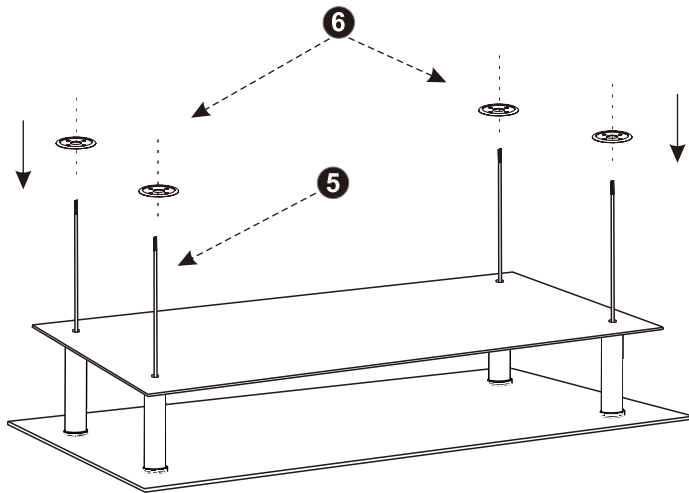

Tip2 :  
please note the front and back when inserting  
the plastic washer

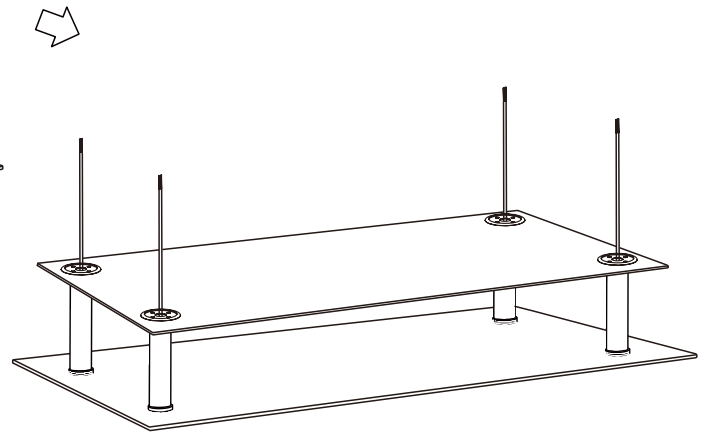

## Step 6

• Insert stainless tube (4) through screw rod(5).

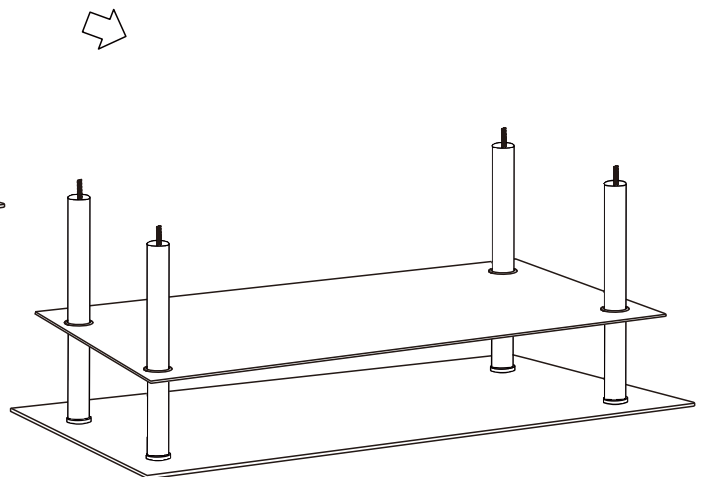
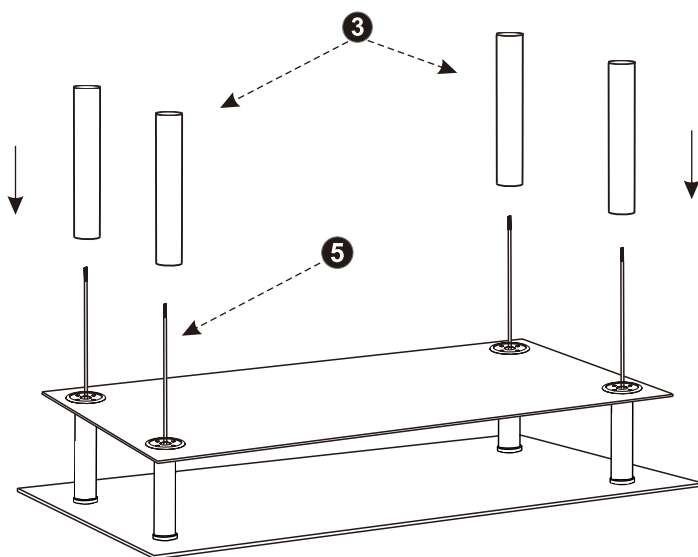



# HODEDAH

[www.hodedah.com](http://www.hodedah.com)

[support@hodedah.com](mailto:support@hodedah.com)

## Step 7

- Insert steel footing (7) and rubber mat (8) through screw rod (5).
- Fix steel washer (B) and nut (A) on screw rod (5), tighten by wrench (C).

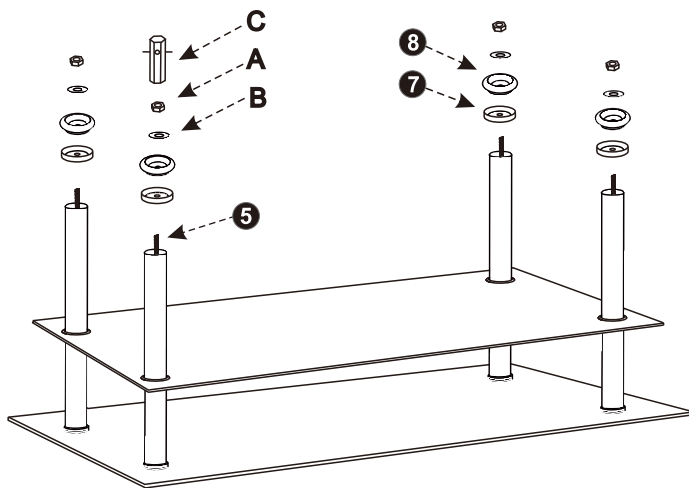

### HARDWARE REQUIRED



4\*A



4\*B

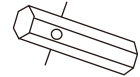

C

Tip3:  
please note the front and back when inserting the steel footing and rubber mat

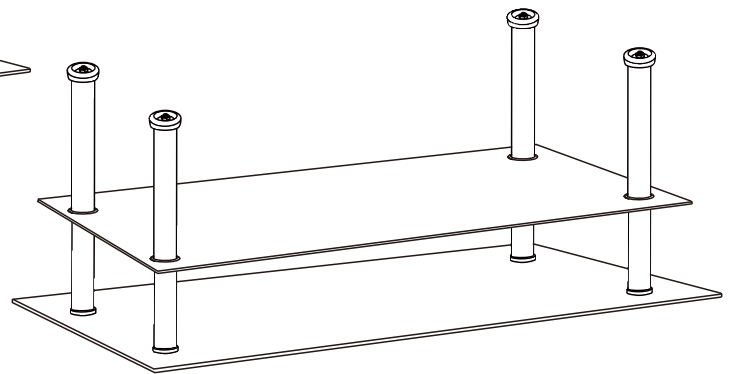

## Step 8

- Turn over the stand and place it on the floor.

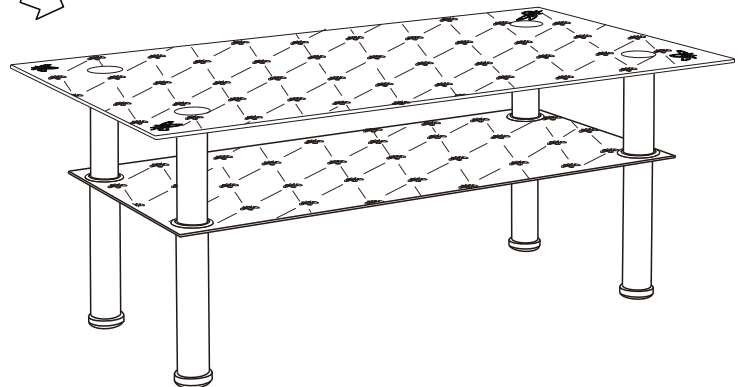
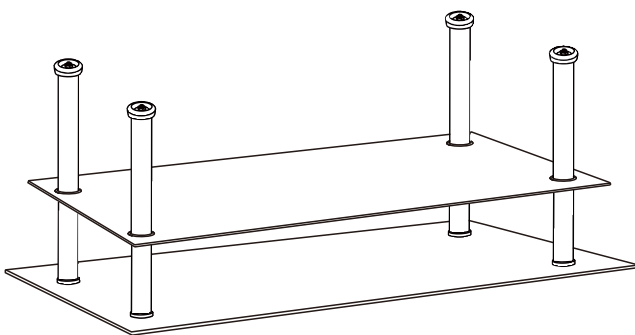

# Job Complete !

In the interest of our environment please dispose of all packaging thoughtfully.





# **HODEDAH**

[www.hodedah.com](http://www.hodedah.com)

[support@hodedah.com](mailto:support@hodedah.com)

## **WARNING!**

- 1. MAKE SURE ALL SCREWS HAVE BEEN PROPERLY TIGHTENED BEFORE USING TV STAND*
- 2. DO NOT PLACE VERY HOT OR VERY COLD ITEMS ON THE GLASS SURFACE UNLESS ADEQUATELY THICK TABLEMATS ARE USED TO PREVENT SUCH ITEMS FROM COMING INTO DIRECT CONTACT WITH GLASS SURFACE*
- 3. DO NOT SIT OR STAND UPON THE GLASS SURFACE*
- 4. DO NOT STRIKE THE GLASS WITH HARD OR POINTED ITEMS*
- 5. WHEN CLEANING THE GLASS USE A DAMP CLOTH ; DO NOT USE WASHING POWDER OR ANY OTHER SUBSTANCE CONTAINING ABRASIVES SINCE THESE SUBSTANCES CAN SCRATCH GLASS*
- 6. IT IS ESSENTIAL THAT THIS UNIT IS FIXED TO A WALL WITH FIXINGS PROVIDED (IF APPLICABLE)*